

# Outline of the Revelation of Jesus Christ

- I. Background
  - A. Author
  - B. Date
  - C. Theme
  - D. Key verse (1:19) *“Write the things which you have seen, and the things which are, and the things which will take place after this.”*
  
- II. Revelation: *“The things which you have seen.”* (1:1-20)
  - A. Seven Golden Lampstands
  - B. Vision of the Glorified Christ
  
- III. Revelation: *“The things which are.”* (2:1-3:22)
  - A. Message to the seven churches
    - 1. Ephesus (2:1-7)
    - 2. Smyrna (2:8-11)
    - 3. Pergamos (2:12-17)
    - 4. Thyatira (2:18-29)
    - 5. Sardis (3:1-6)
    - 6. Philadelphia (3:7-13)
    - 7. Laodicea (3:14-22)
  
- IV. Revelation: *“The things which will take place after this.”* (4:1-22:21)
  - A. Rapture and Judgment of Righteous (4:1,2)
  - B. Heavenly scene
    - 1. Twenty-four elders (4:1-4)
    - 2. Cherubim (4:5-14)
    - 3. Seven-Sealed Book (5:1-4)
    - 4. Lion of Judah breaks the seals (5:5-14)
  - C. Seal judgments
    - 1. **1<sup>st</sup> through 4<sup>th</sup> Seal Judgments: Four Horsemen**
      - a. **White Horse:** Antichrist (6:1-2)
      - b. **Red Horse:** WWII (6:3-4)
      - c. **Black Horse:** World depression except rich (6:5-6)
      - d. **Pale Green Horse:** ¼ of world dies (6:7-8)
    - 2. **5<sup>th</sup> Seal Judgment:** Martyred souls under the alter (6:9-11)
    - 3. **6<sup>th</sup> Seal Judgment:** Great earthquake (6:12-17)
    - 4. **7<sup>th</sup> Seal Judgment:** Is the 7 Trumpet Judgments with a great earthquake (8:1-2)
  - D. Seal of the Living God (7:3)
  - E. Identity of the 144,000 (7:4-8)
  - F. Vast crowd worshipping God (7:9-12)
  - G. Redeemed out of Tribulation before the throne (7:13-17)

- H. Seven Trumpet Judgments (8:2-11:19)
1. **1<sup>st</sup> Trumpet:** Hail and fire mixed with blood, thrown to earth, 1/3 of earth set on fire. 1/3 of trees burned, and all grass burned. (8:7)
  2. **2<sup>nd</sup> Trumpet:** Great mountain of fire thrown into sea. 1/3 of water in sea becomes blood, 1/3 of all things living in sea die. 1/3 of all ships on sea are destroyed. (8:8,9)
  3. **3<sup>rd</sup> Trumpet:** Great flaming star fell out of sky, burning like a torch. Falling on 1/3 of rivers and on springs of water. The name of the star was Bitterness. Making 1/3 of water bitter, and many people die because the water was so bitter. (8:10)
  4. **4<sup>th</sup> Trumpet:** 1/3 of sun is struck, and 1/3 of moon, and 1/3 of stars, and they became dark. 1/3 of the day was dark and 1/3 of the night also. (8:12)
  5. Eagle cries out over world, *“Terror, terror, terror to all who belong to this world because of what will happen when the last three angels blow their trumpets.”* (8:13)
  6. **5<sup>th</sup> Trumpet and 1<sup>st</sup> Terror:** Fallen star (angel) given key to bottomless pit and releases locust with power to sting like scorpions. They are not to hurt the vegetation or anyone with the seal of God. They are not to kill them but to torture them for five months with agony like the pain of scorpion stings. (9:1-12)
  7. **6<sup>th</sup> Trumpet and 2<sup>nd</sup> Terror:** Release of four (fallen) angels who are bound at Euphrates River. They looked like horses with riders sitting on them kill 1/3 of all the people on earth with fire, smoke and burning sulfur that came from the mouths of the horses. (9:13-21)
  8. **7<sup>th</sup> Trumpet is the 3<sup>rd</sup> Terror and the 7 Bowl Judgments** (11:15-19)
- I. Seven Thunders from angel with one foot on the land and one on the sea. (10:1-8)
- J. Small scroll eaten by John (10: 9-11)
- K. Two Witnesses (11:1-14)
- L. The Woman and the Dragon (12:1-6)
- M. Satan cast out from the throne of God to the earth (12:7-12)
- N. Dragon pursues the Woman for 1260 days (12:13-17)
- O. Satan indwells Antichrist on earth after his death and resurrection (13:1-9)
- P. False Prophet and his power described (13:11-18)
- Q. 666 described (13:18)
- R. Redeemed 144,000 described in heaven with Christ (14:1-5)
- S. Three angels fly over the earth and proclaim salvation. (14:6-13)
- T. Song of Moses song by the redeemed that did not worship the Beast and did not take his number (15:1-4)
- U. One of the four living beings handed seven angels a gold bowl filled with the terrible wrath of God. (15:70)

- V. Seven Bowl Judgments
1. **1<sup>st</sup> Bowl Judgment:** Malignant sores break out on everyone who has the mark of the Beast and who worship his statue. (16:2)
  2. **2<sup>nd</sup> Bowl Judgment:** Sea becomes like the blood of a corpse. Everything in the sea die. (16:3)
  3. **3<sup>rd</sup> Bowl Judgment:** Rivers and springs become blood. (16:4)
  4. **4<sup>th</sup> Bowl Judgment:** Sun scorches everyone with fire. (16:8)
  5. **5<sup>th</sup> Bowl Judgment:** The throne of the beast, and his kingdom are plunged into darkness. (16:10)
  6. **6<sup>th</sup> Bowl Judgment:** Euphrates River is dried up allowing kings from the east to march westward. (16:12)
  7. Three evil spirits that look like frogs leap from the mouth of the Dragon, the Beast, and the False Prophet. These miracle-working demons cause all the rulers of the world to gather for battle against the Lord on that great judgment day of God Almighty. (16:13-14)
  8. **7<sup>th</sup> Bowl Judgment:** Mighty shout came from the throne of the Temple in heaven, saying, "*It is finished!*" And there was an earthquake greater than ever before in human history. Babylon is split into three pieces, and cities around the world are destroyed. Every island disappears, and all the mountains are leveled. Hailstones weighing seventy-five pounds fall from the sky onto the people. (16:17-20)
- W. Great prostitute describe and destroyed Mid-Trib (17:1-6)
- X. Beast with seven heads and ten horns (17:7-14)
- Y. Babylon is fallen (18:1-24)
- Z. Marriage Supper of the Lamb (19:1-10)
- A. The Glorious Appearing (19:11-18)
- B. Battle of Armageddon (19: 19-21)
- C. Satan is bound for a 1000 years (20:1-3)
- D. First Resurrection (20:4-6)
- E. Redeemed reign with Christ for a 1000 years (20:6)
- F. Final defeat of Satan (20:10)
- G. Great White Throne of Judgment (20:11-13)
- H. New Jerusalem, Throne of God on earth (21:10-27)
- I. Curse comes to an end! (22:3)

# Revelation Chapter 1

1. Why we need to know Revelation
  - a. Blessings on the reader and those who obey it. (1:3)
  - b. Because it is the Word of God, and we need to understand all of God's Word. He wants us to know what He is really like and what the future holds for the Church and the world.
  - c. Understanding God's plan for this world and our lives will motivate us to live as Christ did. Throughout history, the Christians that understood and studied prophecy were more evangelistic and missionary minded.
  - d. 1/3 of the Bible is prophetic and 99.9% of it has already been completed.
  - e. Understanding prophecy gives us a picture of our Lord as He really is and arms us against false prophets and cults. Knowing what the Bible teaches makes us less vulnerable to deception.
  - f. Knowing prophecy gives us hope and confidence in a world of war and pain.
  - g. Knowing that Christ will return at any minute makes us more aware of our current behavior. We find ourselves asking, "Do I want to be doing this when Christ returns?"
2. Pre-Tribulation and pre-Millennial perspective
  - a. Pre-Tribulation meaning that the rapture will happen before the Tribulation
  - b. Pre-Millennial meaning that Christ will return to the earth, literally and bodily, before the Millennium. And the Millennium will take place after the Tribulation and after the Glorious Appearing.
  - c. It is imperative to point out that many Christians have different views about this. We should be dogmatic about certain doctrines such as the virgin birth, the deity of Christ, the inerrancy of Scriptures, the need to be born again, salvation through faith and others including the fact that Christ is going to return but this does not mean that we can be totally dogmatic about the time.

- d. The Bible was not given to separate us but to bind us together. Study the scriptures for yourself and do not believe everything you are told. Read the Word and ask for the guidance of the Holy Spirit and seek to understand what God wants you to know.
3. Notes on interpretation of Revelation
    - a. Golden Rule of Interpretation: When the plain sense of scripture makes common sense, seek no other sense.
    - b. Locate the scene of activity, heaven or earth.
    - c. With the exception of Chapters 12 and 17 the Book of Revelation unfolds chronologically.

### **Revelation 1:1-3**

*This is a revelation from Jesus Christ, which God gave him concerning the events that will happen soon. An angel was sent to God's servant John so that John could share the revelation with God's other servants. <sup>2</sup> John faithfully reported the word of God and the testimony of Jesus Christ—everything he saw. <sup>3</sup> God blesses the one who reads this prophecy to the church, and he blesses all who listen to it and obey what it says. For the time is near when these things will happen.*

4. Theme
  - a. This is the revelation of Jesus Christ, not as the disciples had known him, but as whom He really was and is. They had only seen Him as the Lamb led to slaughter and not as a Judge. They saw Him as the Lamb of God and not as the Lion of Judah. This book reveals Jesus as He is and would be in the future. The Church needed to know what the future of the world would be.
5. Author
  - a. The Apostle John wrote the book as directed by an angel. The true source of the book of Revelation is God. It came from God to Christ to an angel to John and then to the Church.
  - b. It was written about AD 95 when John was exiled to the Island of Patmos. He was sent there by Domitian (AD 91-96) for, as John stated, "*The Word of God and the testimony of Jesus Christ.*"

- c. John was the leader of the church of Ephesus at the time and he was the last living apostle. The only one to die a natural death. He was very old at the time. The island was a very desolate rock and prisoners were made to work in the quarries.

### **Revelation 1:4-8**

<sup>4</sup> *This letter is from John to the seven churches in the province of Asia. Grace and peace from the one who is, who always was, and who is still to come; from the sevenfold Spirit before his throne; <sup>5</sup> and from Jesus Christ, who is the faithful witness to these things, the first to rise from the dead, and the commander of all the rulers of the world. All praise to him who loves us and has freed us from our sins by shedding his blood for us. <sup>6</sup> He has made us his kingdom and his priests who serve before God his Father. Give to him everlasting glory! He rules forever and ever! Amen!*

<sup>7</sup> *Look! He comes with the clouds of heaven. And everyone will see him—even those who pierced him. And all the nations of the earth will weep because of him. Yes! Amen! <sup>8</sup> “I am the Alpha and the Omega—the beginning and the end,” says the Lord God. “I am the one who is, who always was, and who is still to come, the Almighty One.”*

6. John gives us the information about how the revelation came to him. He is on the earth and he is seeing Christ as He really is. John actually sees Christ return at the Glorious Appearing in verse 7. Christ reveals to John that there is nothing outside of Him. He is the Beginning and He is the End! These are the things which John had seen.

### **Revelation 1:9-16**

<sup>9</sup> *I am John, your brother. In Jesus we are partners in suffering and in the Kingdom and in patient endurance. I was exiled to the island of Patmos for preaching the word of God and speaking about Jesus. <sup>10</sup> It was the Lord’s Day, and I was worshiping in the Spirit. Suddenly, I heard a loud voice behind me, a voice that sounded like a trumpet blast. <sup>11</sup> It said, “Write down what you see, and send it to the seven churches: Ephesus, Smyrna, Pergamum, Thyatira, Sardis, Philadelphia, and Laodicea.”*

<sup>12</sup> *When I turned to see who was speaking to me, I saw seven gold lampstands.*

<sup>13</sup> *And standing in the middle of the lampstands was the Son of Man. He was wearing a long robe with a gold sash across his chest. <sup>14</sup> His head and his hair were white like wool, as white as snow. And his eyes were bright like flames of fire. <sup>15</sup> His feet were as bright as bronze refined in a furnace, and his voice thundered like mighty ocean waves. <sup>16</sup> He held seven stars in his right hand, and a sharp two-edged sword came from his mouth. And his face was as bright as the sun in all its brilliance.*

7. The Seven Lampstands (1:12)
  - a. The Christ that John describes is not like anything he has ever seen before. He sees seven golden lampstands with Christ in the middle.
  - b. Christ Himself tells John that the seven lampstands are the seven churches in verse 20 of chapter 1.
  - c. The Seven Stars are either the pastor-messengers of the churches or the guardian angels assigned to the churches.
  
8. Vision of Christ (1:12-16)
  - a. John saw the Glorious Appearing when Christ comes back to earth and he shouts, "*Look, behold He comes in the clouds.*"
  - b. John describes the Christ that he saw. This description of Christ will be revealed to the seven churches. This is how the world will see Him when He returns at the Glorious Appearing.
  
9. There is divided opinion regarding the meaning of the message Christ gave to John for the seven churches. It is generally agreed that these messages have four applications. Most Biblical scholars agree on these applications.
  - a. **The Seven Churches of John's Day:**  
Obviously there were literal churches with which John was familiar. But you have to ask yourself why Christ chose these seven churches when there were hundreds of them. This was about 63 years after Pentecost and there were churches located all over the world at this time. Which leads to the suggestion that they also represent the seven basic divisions of church history.
  - b. **The Seven Basic Divisions of Church History:**  
A study of history reveals that the Church has gone through seven basic periods. Many prophecy scholars show how they parallel Christ's message to the seven churches. Most premillennialists hold this position.
  - c. **The Seven Types of Churches That Exist Today:**  
Although most of these phases of church history are concluded, their influence still carries over from stage to stage and some trends are still in existence today.

d. **The Seven Characteristics That Can Exist in Any Church or Christian:**

This is the practical application of the message to churches and individuals. As we look at the message to the churches, we can see seven methods of attack by Satan on the Church or the individual Christian.

Revelation 1:17-20

*<sup>17</sup> When I saw him, I fell at his feet as dead. But he laid his right hand on me and said, "Don't be afraid! I am the First and the Last. <sup>18</sup> I am the living one who died. Look, I am alive forever and ever! And I hold the keys of death and the grave. <sup>19</sup> Write down what you have seen—both the things that are now happening and the things that will happen later. <sup>20</sup> This is the meaning of the seven stars you saw in my right hand and the seven gold lampstands: The seven stars are the angels of the seven churches, and the seven lampstands are the seven churches."*

10. Key verse is Revelation 1:19 *"Write the things which you have seen, and the things which are, and the things which will take place after this."*
  - a. The things you have seen.
  - b. The things that are present.
  - c. The things that will be.
11. *"The things you have seen."*
  - a. Chapter one covers the *"things you have seen."* John gives us a description of what he saw when Christ returned to the earth.
12. *"The things that are present."*
  - a. Chapters 2 and 3 give us the *"things that are present."* Christ gives a message to the 7 churches. These churches were active at the time John wrote the Revelation of Jesus Christ.

## Revelation Chapter 2

Christ gives to each of the churches and the church ages a different description of Himself. It is the same description given by John. He also gives each a commendation, a criticism, a correction, a judgment and a promise. As with each literal church, this holds true for the different church ages, for the individual churches and for Christians today.

### **Revelation 2:1-7**

*Write this letter to the angel of the church in Ephesus. This is the message from the one who holds the seven stars in his right hand, the one who walks among the seven gold lampstands: <sup>2</sup> I know all the things you do. I have seen your hard work and your patient endurance. I know you don't tolerate evil people. You have examined the claims of those who say they are apostles but are not. You have discovered they are liars. <sup>3</sup> You have patiently suffered for me without quitting. <sup>4</sup> But I have this complaint against you. You don't love me or each other as you did at first! <sup>5</sup> Look how far you have fallen from your first love! Turn back to me again and work as you did at first. If you don't, I will come and remove your lampstand from its place among the churches. <sup>6</sup> But there is this about you that is good: You hate the deeds of the immoral Nicolaitans, just as I do. <sup>7</sup> Anyone who is willing to hear should listen to the Spirit and understand what the Spirit is saying to the churches. Everyone who is victorious will eat from the tree of life in the paradise of God.*

Take out addendum number 1 "The Seven Churches of Revelation."

1. The Church of Ephesus
  - a. The actual church was located in Ephesus and was the church that John was the head of when he was taken into exile. Paul, at the end of his 2nd missionary trip started this church. (Acts 18:19-20)
  - b. Represents the Apostolic Church from Pentecost to 100AD.
  - c. Christ stated, "*I know your works, I know you can not tolerate wicked men; I know you have persevered and endured hard times.*" This church was known for fervent evangelism under Jewish leadership and hated the deeds of the Nicolaitans. This was a movement of followers of Nicolai. They practiced the separation of ones spiritual and physical self. This gave them license to sin. They established the ecclesiastical order of priests

and bishops. Local churches became controlled by one man or group of men and the followers looked to them for answers and not to the Holy Spirit.

- d. But this church had lost its first love. They were faithful but their relationship with Christ had become common place.
- e. Christ tells them to remember where they once were and to repent and return to that place. The judgment was to remove their lampstand or place among the churches. If they did repent, the over comers were promised access to the Tree of Life.
- f. Christ states, to those spiritually minded individuals and churches, to hear what the Spirit is saying. As a church or an individual, we need to stay connected to the Holy Spirit. And to receive a fresh and a continually new in-filling from Him. It is like manna. It had to be collected each day and could not be stored. If we become dull, we loose our flavor and become useless to Christ as a member of the Body. We keep connected to Christ by prayer and reading His Word and asking the Holy Spirit to keep us fresh.

### **Revelation 2:6-11**

*<sup>8</sup> Write this letter to the angel of the church in Smyrna. This is the message from the one who is the First and the Last, who died and is alive: <sup>9</sup> I know about your suffering and your poverty—but you are rich! I know the slander of those opposing you. They say they are Jews, but they really aren't because theirs is a synagogue of Satan. <sup>10</sup> Don't be afraid of what you are about to suffer. The Devil will throw some of you into prison and put you to the test. You will be persecuted for 'ten days.' Remain faithful even when facing death and I will give you the crown of life. <sup>11</sup> Anyone who is willing to hear should listen to the Spirit and understand what the Spirit is saying to the churches. Whoever is victorious will not be hurt by the second death.*

## 2. The Church of Smyrna

- a. The actual church was located in the city of Smyrna, a very wealthy city that had little time for Christians. It was a commercial center of Asia Minor and on a direct trade route from India and Persia to Rome. This church was the most faithful in times of very difficult persecution.
- b. Represents the Persecuted Church Age from 100 AD to 312 AD. This was one of the greatest periods of Christian persecution second only to

today. Roman emperors held public burnings of the sacred scripture. Remember the only scripture they had was hand written. And not everyone could read and write, so what they had was very limited. This was the period of time when Christians were thrown to the lions. Many were crucified; others were covered in animal skins and tortured to death by wild dogs. They were covered with tar and set on fire to serve as torches in the emperor's garden. They were boiled in oil and burned at the stake. One estimate by historians is that 5 million Christians were martyred during this time. Satan thought he had a good strategy to get rid of the Church, but the more he persecuted them, the more the Church grew. This church was also very poor. They were prevented from work because it was illegal to be a Christian at that time, so they had to hide their faith to work or trade. They lived during a very wealthy time but were prevented from the wealth.

- c. Christ said, I know your afflictions, I know your poverty, but I see you as very rich. And He had not one word of criticism for them.
- d. This church was very faithful to the Word and was led by the Holy Spirit so many people came to know Christ as Savior despite Satan's attempts to kill them. He was working from the outside of the Church trying to destroy the work of God.
- e. Christ told them to fear not even unto death with no judgment. And they were promised a Crown of Life and no Second Death, which is complete separation from God in the Lake of Fire.

### **Revelation 2:12-17**

*<sup>12</sup> Write this letter to the angel of the church in Pergamum. This is the message from the one who has a sharp two-edged sword: <sup>13</sup> I know that you live in the city where that great throne of Satan is located, and yet you have remained loyal to me. And you refused to deny me even when Antipas, my faithful witness, was martyred among you by Satan's followers. <sup>14</sup> And yet I have a few complaints against you. You tolerate some among you who are like Balaam, who showed Balak how to trip up the people of Israel. He taught them to worship idols by eating food offered to idols and by committing sexual sin. <sup>15</sup> In the same way, you have some Nicolaitans among you—people who follow the same teaching and commit the same sins. <sup>16</sup> Repent or I will come to you suddenly and fight against them with the sword of my mouth. <sup>17</sup> Anyone who is willing to hear should listen to the Spirit and understand what the Spirit is saying to the churches. Everyone who is victorious will eat of the*

*manna that has been hidden away in heaven. And I will give to each one a white stone, and on the stone will be engraved a new name that no one knows except the one who receives it.*

### 3. The Church of Pergamos

- a. The actual church was located in the city of Pergamum, which was the capitol of Asia and Satan's capitol. Babylon had been Satan's capitol, as idolatry started there with Nimrod, (Genesis 11) but as Babylon's power faded, Satan looked for a new capitol and settled in Pergamum because of its strong idolatrous religions. So many people were open to deception.
- b. Represents the Indulged Church of AD 312-606. Satan had learned from his attacks on the Persecuted Church what he was doing was not working and looked for a new strategy. After Diocletian's unsuccessful attacks on the Church, Constantine (306-337 AD) succeeded him as emperor. Roman history tells us that he saw a vision of God that told him he would be become emperor if he embraced Christianity. So he accepted the Christian faith and declared Christianity the State religion. Satan is now going to try and defeat the Church from the inside out. There were many pagan temples in Rome at this time and many made their living off of these false gods. Constantine gave the Church all of these temples. Only the pagans did not leave. The Church and these pagan religions combined and the Church took on many false teachers and doctrine. From 312 AD the Church became more Roman than Christian. Christianity became lost in the pagan rituals.
- c. Christ states, *"I know you live where Satan has his throne and yet you remain true to my name, but you have taken on false teachers and the doctrine of Balaam and the Nicolaitans."*
- d. Although their theology may have been right, some had taken on pagan rituals and doctrines. They knew Jesus was God and a sinless man and was born of a virgin, but they needed to repent or judgment would come soon with warfare against the Church with the sword of Christ's mouth.
- e. To those who did remain faithful and repent of the false doctrine, He promised hidden manna and possession of a white stone and new name.

## **Revelation 2:18-29**

<sup>18</sup> Write this letter to the angel of the church in Thyatira. This is the message from the Son of God, whose eyes are bright like flames of fire, whose feet are like polished bronze: <sup>19</sup> I know all the things you do—your love, your faith, your service, and your patient endurance. And I can see your constant improvement in all these things. <sup>20</sup> But I have this complaint against you. You are permitting that woman—that Jezebel who calls herself a prophet—to lead my servants astray. She is encouraging them to worship idols, eat food offered to idols, and commit sexual sin. <sup>21</sup> I gave her time to repent, but she would not turn away from her immorality. <sup>22</sup> Therefore, I will throw her upon a sickbed, and she will suffer greatly with all who commit adultery with her, unless they turn away from all their evil deeds. <sup>23</sup> I will strike her children dead. And all the churches will know that I am the one who searches out the thoughts and intentions of every person. And I will give to each of you whatever you deserve. <sup>24</sup> But I also have a message for the rest of you in Thyatira who have not followed this false teaching (‘deeper truths,’ as they call them—depths of Satan, really). I will ask nothing more of you <sup>25</sup> except that you hold tightly to what you have until I come. <sup>26</sup> “To all who are victorious, who obey me to the very end, I will give authority over all the nations. <sup>27</sup> They will rule the nations with an iron rod and smash them like clay pots. <sup>28</sup> They will have the same authority I received from my Father, and I will also give them the morning star! <sup>29</sup> Anyone who is willing to hear should listen to the Spirit and understand what the Spirit is saying to the churches.

### 4. The Church of Thyatira

- a. Thyatira was also a very wealthy church and was known for its colored dyes.
- b. Represents the Pagan Church Age or Dark Ages from AD 606 to the Tribulation. This church had introduced the pagan rituals and had diluted the gospel of Christ. They were doctrinally sound as far as the deity of Christ was concerned, but the Church of Pergamum merged paganism with Christianity and increasingly emphasized paganism which is darkness. The light that Christ had entrusted to the Church all but flickered out during the Dark Ages and was not rekindled until the Reformation. John Wycliffe (1330-1384) started the climb out of the Dark Ages by determining that the Bible should be in a common language so everyone could read it, not just the priests. The Church held all the power by keeping the Word from the people. Telling them that they, the

priests had the truth. Satan is still using this strategy today, that is why it so important for us to know what the Word states.

- c. Christ stated, *“I know your deeds, your love, your service and that you are doing more now than in the beginning. But you have tolerated that woman Jezebel.”* Jezebel represents sexual sin. The Church denied the finished work of Christ. Emphasizing more on works than grace. They taught continual sacrifices and grew farther away from the sacrifice made once and for all by Christ Jesus. All of this was borrowed from mysterious Babylon and none of it was taught in the New Testament. The Church gradually became more Babylonian than Christian. Salvation came from works and not from grace. They believed in the deity of Christ and the Virgin Birth, but incorporated many pagan rituals and diluted the Christian message.
- d. Christ warns them that if they do not throw out Jezebel (sexual sin), or the paganism, they will go through the Tribulation and see the killing of their children. To those who do remain faithful to the Truth and overcome, they are promised power over the nations and possession of the Morning Star.

## Revelation Chapter 3

### Revelation 3:1-6

*Write this letter to the angel of the church in Sardis. This is the message from the one who has the sevenfold Spirit of God and the seven stars: I know all the things you do, and that you have a reputation for being alive—but you are dead. <sup>2</sup> Now wake up! Strengthen what little remains, for even what is left is at the point of death. Your deeds are far from right in the sight of God. <sup>3</sup> Go back to what you heard and believed at first; hold to it firmly and turn to me again. Unless you do, I will come upon you suddenly, as unexpected as a thief. <sup>4</sup> “Yet even in Sardis there are some who have not soiled their garments with evil deeds. They will walk with me in white, for they are worthy. <sup>5</sup> All who are victorious will be clothed in white. I will never erase their names from the Book of Life, but I will announce before my Father and his angels that they are mine. <sup>6</sup> Anyone who is willing to hear should listen to the Spirit and understand what the Spirit is saying to the churches.*

1. The Church of Sardis
  - a. Sardis was the capitol city of Lydia and was noted for its carpets. The local church had a good name, but was basically a dead church.
  - b. This represents the Dead Church from AD 1520 to the Tribulation. This is the period of the Reformation. This happened because of the continual emphasis on the pagan rituals rather than adhering to scriptural principles. As Martin Luther quoted, “But the righteous will live by faith.” They started out good, but soon became state churches and sought approval from political leaders, thus eliminating the need for a personal relationship with Christ. They sought to please the government and not God.
  - c. Christ states to them, “*I know your deeds and you have a reputation of being alive, but you are dead.*” He tells them to wake up and strengthen what remains, to repent before is too late, and that He is coming like a thief in the night.
  - d. A few had not defiled their garments and had kept the faith and Christ tells them to keep up their faith and strengthen what they have and to those that overcome, He promised white garments and permanence in the Book of Life.

### **Revelation 3:7-13**

<sup>7</sup> Write this letter to the angel of the church in Philadelphia. This is the message from the one who is holy and true. He is the one who has the key of David. He opens doors, and no one can shut them; he shuts doors, and no one can open them. <sup>8</sup> I know all the things you do, and I have opened a door for you that no one can shut. You have little strength, yet you obeyed my word and did not deny me. <sup>9</sup> Look! I will force those who belong to Satan—those liars who say they are Jews but are not—to come and bow down at your feet. They will acknowledge that you are the ones I love. <sup>10</sup> Because you have obeyed my command to persevere, I will protect you from the great time of testing that will come upon the whole world to test those who belong to this world. <sup>11</sup> Look, I am coming quickly. Hold on to what you have, so that no one will take away your crown. <sup>12</sup> All who are victorious will become pillars in the Temple of my God, and they will never have to leave it. And I will write my God's name on them, and they will be citizens in the city of my God—the new Jerusalem that comes down from heaven from my God. And they will have my new name inscribed upon them. <sup>13</sup> Anyone who is willing to hear should listen to the Spirit and understand what the Spirit is saying to the churches.

## 2. The Church of Philadelphia

- a. The city of Philadelphia was located in the middle of Greek civilization and remained a Christian city until the Turks conquered it in the 14<sup>th</sup> century.
- b. This church represents the Church that Christ loved from AD 1750 to the Rapture. After the Reformation, the Church became a cold state church. But the Spirit of God began to move on individuals and the first missionary movement began. This was sparked by an interest in the Second Coming of Christ. One factor that contributed to this movement was the printing of the Bible. As it became more available people turned back to scripture and this increased their zeal for missions and evangelism. This Church looked forward to the Second Coming of Christ. Because of this, they had a more zealous approach to evangelism and missions. This is true of any church or Christian today.
- c. Christ said, “*I know your deeds, you have little strength, but you have kept my Word.*” This church not only believed the Word of God, but kept it. They did not deny the name of Christ. There was no complaint from Christ and no judgment. Christ promised deliverance from the Tribulation and the new name of God. He tells them to hold on to what they have as He is coming soon.

- d. This is the Church we are a part of today. As “Born-Again” Christians, we not only believe His Word, but also keep it. We look forward to His return and tell others about Him. This Church will not go through the Tribulation, but will be removed from the earth before it starts.

### **Revelation 3:14-22**

*<sup>14</sup> Write this letter to the angel of the church in Laodicea. This is the message from the one who is the Amen—the faithful and true witness, the ruler of God’s creation: <sup>15</sup> I know all the things you do, that you are neither hot nor cold. I wish you were one or the other! <sup>16</sup> But since you are like lukewarm water, I will spit you out of my mouth! <sup>17</sup> You say, ‘I am rich. I have everything I want. I don’t need a thing!’ And you don’t realize that you are wretched and miserable and poor and blind and naked. <sup>18</sup> I advise you to buy gold from me—gold that has been purified by fire. Then you will be rich. And also buy white garments so you will not be shamed by your nakedness. And buy ointment for your eyes so you will be able to see. <sup>19</sup> I am the one who corrects and disciplines everyone I love. Be diligent and turn from your indifference. <sup>20</sup> Look! Here I stand at the door and knock. If you hear me calling and open the door, I will come in, and we will share a meal as friends. <sup>21</sup> I will invite everyone who is victorious to sit with me on my throne, just as I was victorious and sat with my Father on his throne. <sup>22</sup> Anyone who is willing to hear should listen to the Spirit and understand what the Spirit is saying to the churches.*

### 3. The Church of Laodicea

- a. Laodicea was a wealthy Greek city located inland. This church was very wealthy and in spite of her wealth there is little know about the ministry of this church.
- b. This represents the Apostate Church from AD 1900 to the Tribulation.
- c. There is no commendation from Christ. There is nothing good about this church. This ecumenical apostate church is gaining momentum today. It encompasses all religions and does not adhere to salvation through Christ and allows any god into doctrine. There is not one way to God, all are accepted. It says to herself, I am rich, but she is poor. Her churches are the finest million-dollar buildings with very large membership. This church does not glorify the name of Christ but depends on her wealth and her own means. It glorifies humanity and not the Spirit of God. They rely on their own power and do not acknowledge the power of the Holy Spirit. This church will go through the Tribulation.

- d. This is the luke warm church that Christ will spit out. They have over estimated their status with God. They think they have status, but have none. They need to seek genuine spiritual riches and repent. Christ will expel them from His mouth if they do not. But those who do, He promises an intimate relationship with Himself.

## Revelation Chapter 4

1. *“The things which will take place after this.”* (4:1-22:21)
  - a. Looking at the beginning of Chapter 4, we see John on earth and looking at a door open to heaven. He hears a voice telling him, *“to come up here.”* John is now in heaven. This is no coincidence that the first thing to happen to John after the description of the Seven Churches is that he is taken to heaven. His elevation to heaven represents the Rapture of the Church just before the Tribulation period.
  - b. 2 Thessalonians 2:7-8 states, *“the lawless one or Antichrist is being restrained and that the restraints will be removed.”* The Restrainer is the Holy Spirit working through the prayers of the Church. After the Rapture happens, there will be a period of time when there will be no Christians praying and no vessels for the Holy Spirit to work through. Many will soon be converted and the Holy Spirit will continue to work to bring people to Christ, but for a period of time, the world will be without a praying Church to restrain complete lawlessness. Think of this world without the praying Church. And even though there will be many who come to Christ because of His judgments, many will also be deceived because they turned Christ away when they had a chance to receive His grace as stated in 2 Thessalonians 2:9-12.

### **Revelation 4:1-4**

*<sup>1</sup> Then as I looked, I saw a door standing open in heaven, and the same voice I had heard before spoke to me with the sound of a mighty trumpet blast. The voice said, ‘Come up here, and I will show you what must happen after these things.’ <sup>2</sup> And instantly I was in the Spirit, and I saw a throne in heaven and someone sitting on it! <sup>3</sup> The one sitting on the throne was as brilliant as gemstones—jasper and carnelian. And the glow of an emerald circled his throne like a rainbow. <sup>4</sup> Twenty-four thrones surrounded him, and twenty-four elders sat on them. They were all clothed in white and had gold crowns on their heads.*

2. Verse 1 tells us that John has been on earth and now he is being transported into heaven. This verse supports the Pre Tribulation rapture. The Church Age has been completed and Daniel’s 70<sup>th</sup> week is about to begin and the Church, who has not rejected Christ will be spared from the Tribulation. As stated in Rev. 3: 10, *“Because you have obeyed my command to persevere, I will protect you from the great time of testing that will come upon the whole world to test those who belong to this world.”* John is transported directly into heaven as we will be directly transported when the Rapture happens.

3. The 24 elders are redeemed men because they wore white garments and had crowns on their heads. This means that they lived as humans on the earth and were saved from their sins by the Blood of the Lamb. Either they looked forward to the cross or they lived after Christ died. The 24 elders possibly represent the twelve tribes of Israel and the twelve apostles.

### **Revelation 4:5-11**

<sup>5</sup> *And from the throne came flashes of lightning and the rumble of thunder. And in front of the throne were seven lampstands with burning flames. They are the seven spirits of God.* <sup>6</sup> *In front of the throne was a shiny sea of glass, sparkling like crystal. In the center and around the throne were four living beings, each covered with eyes, front and back.* <sup>7</sup> *The first of these living beings had the form of a lion; the second looked like an ox; the third had a human face; and the fourth had the form of an eagle with wings spread out as though in flight.* <sup>8</sup> *Each of these living beings had six wings, and their wings were covered with eyes, inside and out. Day after day and night after night they keep on saying, “Holy, holy, holy is the Lord God Almighty—the one who always was, who is, and who is still to come.”* <sup>9</sup> *Whenever the living beings give glory and honor and thanks to the one sitting on the throne, the one who lives forever and ever,* <sup>10</sup> *the twenty-four elders fall down and worship the One who lives forever and ever. And they lay their crowns before the throne and say,* <sup>11</sup> *You are worthy, O Lord our God, to receive glory and honor and power. For you created everything and it is for your pleasure that they exist and were created.*

4. These creatures are angels that sit before the throne of God and say, “*Holy, holy, holy is the Lord God Almighty.*”
5. We are getting our first view of heaven and it is a very supernatural site. Our human senses cannot imagine what John is seeing. His descriptions are done from a 1<sup>st</sup> century view point and of what was understood at that time.

## Revelation Chapter 5

Revelation 5:1-14

*And I saw a scroll in the right hand of the one who was sitting on the throne. There was writing on the inside and the outside of the scroll, and it was sealed with seven seals. <sup>2</sup> And I saw a strong angel, who shouted with a loud voice: “Who is worthy to break the seals on this scroll and unroll it?” <sup>3</sup> But no one in heaven or on earth or under the earth was able to open the scroll and read it. <sup>4</sup> Then I wept because no one could be found who was worthy to open the scroll and read it. <sup>5</sup> But one of the twenty-four elders said to me, “Stop weeping! Look, the Lion of the tribe of Judah, the heir to David’s throne, has conquered. He is worthy to open the scroll and break its seven seals.” <sup>6</sup> I looked and I saw a Lamb that had been killed but was now standing between the throne and the four living beings and among the twenty-four elders. He had seven horns and seven eyes, which are the seven spirits of God that are sent out into every part of the earth. <sup>7</sup> He stepped forward and took the scroll from the right hand of the one sitting on the throne. <sup>8</sup> And as he took the scroll, the four living beings and the twenty-four elders fell down before the Lamb. Each one had a harp, and they held gold bowls filled with incense—the prayers of God’s people! <sup>9</sup> And they sang a new song with these words: “You are worthy to take the scroll and break its seals and open it. For you were killed, and your blood has ransomed people for God from every tribe and language and people and nation. <sup>10</sup> And you have caused them to become God’s kingdom and his priests. And they will reign on the earth.” <sup>11</sup> Then I looked again, and I heard the singing of thousands and millions of angels around the throne and the living beings and the elders. <sup>12</sup> And they sang in a mighty chorus: “The Lamb is worthy—the Lamb who was killed. He is worthy to receive power and riches and wisdom and strength and honor and glory and blessing.” <sup>13</sup> And then I heard every creature in heaven and on earth and under the earth and in the sea. They also sang: “Blessing and honor and glory and power belong to the one sitting on the throne and to the Lamb forever and ever.” <sup>14</sup> And the four living beings said, “Amen!” And the twenty-four elders fell down and worshiped God and the Lamb.*

1. The Book with 7 seals represents the deed to the earth, and Christ is the only One worthy to open it. When Christ opens the seals, this will begin God’s judgment. The judgment will be for the Jewish people because they rejected Christ and for the world that has also rejected Him. This is the transition from a time of Grace to a time of Judgment. God’s patience has run out. Remember that God is holy and can do only good. It is difficult to understand that there will be good in what is about to happen. But many people will turn to Christ to be saved during this time.

Take out addendum number 2 “Daniel’s 70 Weeks” and chart of 70 week prophecy.

## Revelation Chapter 6

Take out addendum 3 the Seal, Trumpet and Bowl Judgments chart

### Revelation 6:1-2

*As I watched, the Lamb broke the first of the seven seals on the scroll. Then one of the four living beings called out with a voice that sounded like thunder, "Come!"*<sup>2</sup> *I looked up and saw a white horse. Its rider carried a bow, and a crown was placed on his head. He rode out to win many battles and gain the victory.*

1. **1<sup>st</sup> Seal or White Horse.** The rider on this horse is not Christ but is the Antichrist and he will conquer by diplomacy. With Christ breaking the first seal, this releases the Antichrist to start his rise to power. He starts out looking good, using diplomacy to gain world control. Because he is carrying a bow without any arrows, he will have the appearance of power but will not use it at first.

### Revelation 6:3-4

*<sup>3</sup> When the Lamb broke the second seal, I heard the second living being say, "Come!"*<sup>4</sup> *And another horse appeared, a red one. Its rider was given a mighty sword and the authority to remove peace from the earth. And there was war and slaughter everywhere.*

2. **2<sup>nd</sup> Seal or Red Horse.** This rider will bring a great world war. After the Rapture and all of the world confusion that will take place and with the rise of Antichrist, not all the nations are going to be happy and this will cause a great war bigger than any other war ever seen by man, but it is only the first of many to come.

### Revelation 6:5-6

*<sup>5</sup> When the Lamb broke the third seal, I heard the third living being say, "Come!" And I looked up and saw a black horse, and its rider was holding a pair of scales in his hand.*<sup>6</sup> *And a voice from among the four living beings said, "A loaf of wheat bread or three loaves of barley for a day's pay. And don't waste the olive oil and wine."*

3. **3<sup>rd</sup> Seal or Black Horse.** This rider is a symbol of famine. Following war a famine will come. But this famine will be greater and more world wide than any that has taken place so far. "And don't waste the olive oil and wine," indicates the rich will be spared at this time.

### **Revelation 6:7-8**

<sup>7</sup> *And when the Lamb broke the fourth seal, I heard the fourth living being say, “Come!”* <sup>8</sup> *And I looked up and saw a horse whose color was pale green like a corpse. And Death was the name of its rider, who was followed around by the Grave. They were given authority over one-fourth of the earth, to kill with the sword and famine and disease and wild animals.*

4. **4<sup>th</sup> Seal or Pale Horse.** The color of this horse is the sick pale green color a dead body takes on after being dead for some time. He represents death and ¼ of world’s population will die. There are about 6 billion people in the world today. So by our population today that would mean that 1.5 billion people would die by the end of this judgment.

### **Revelation 6:9-11**

<sup>9</sup> *And when the Lamb broke the fifth seal, I saw under the altar the souls of all who had been martyred for the word of God and for being faithful in their witness.* <sup>10</sup> *They called loudly to the Lord and said, “O Sovereign Lord, holy and true, how long will it be before you judge the people who belong to this world for what they have done to us? When will you avenge our blood against these people?”* <sup>11</sup> *Then a white robe was given to each of them. And they were told to rest a little longer until the full number of their brothers and sisters—their fellow servants of Jesus—had been martyred.*

5. **5<sup>th</sup> Seal Judgment.** This is the introduction of the fact that there will be a great soul harvest during the Tribulation. The opening of the 5<sup>th</sup> seal tells us there will be a great persecution for those who come to salvation through Christ. These are Tribulation Saints, people who did not receive Christ before the Rapture and were left behind, but did receive Him as a result of the witnesses described in chapter 7 and because of God’s judgments. They will be martyred because of the Word of God and the testimony they maintain. Even though these saints inquire of the Lord, “*How long, Sovereign Lord,*” many others will be killed for their testimony and join them. The prayer of those under the altar will not deter persecution, because it is a time that must be completed. We know these are believers because they are clothed in white robes.

### **Revelation 6:12-17**

<sup>12</sup> *I watched as the Lamb broke the sixth seal, and there was a great earthquake. The sun became as dark as black cloth, and the moon became as red as blood.* <sup>13</sup> *Then the stars of the sky fell to the earth like green figs falling from trees shaken by mighty winds.* <sup>14</sup> *And the sky was rolled up like a scroll and taken away. And all of the mountains and all of the islands disappeared.* <sup>15</sup> *Then the kings of the earth, the rulers, the generals, the wealthy people, the people with great power, and every slave and every free person—all hid*

*themselves in the caves and among the rocks of the mountains.* <sup>16</sup> *And they cried to the mountains and the rocks, “Fall on us and hide us from the face of the one who sits on the throne and from the wrath of the Lamb.”* <sup>17</sup> *For the great day of their wrath has come, and who will be able to survive?”*

6. **6<sup>th</sup> Seal Judgment.** This is an earthquake that will shake the entire world. God is angry for the persecution of His saints. Meteors will fall to the ground. Between the earthquake and the meteors, there will be great changes on the face of the earth. Great fear will grip the hearts of the people.
7. It is evident that they know that this is a judgment of Jesus Christ as they refer to Him as, “*The Lamb.*” These people are fully aware they are in the Tribulation period and know there is no place to hide, but still they do not turn to God.
8. The first 21 months of the Tribulation consist of horrifying events. After the Antichrist assumes worldwide control, there will be world war, famine, inflation and the death of 25% of the world’s population. There is a great multitude that will be saved and they will be persecuted and martyred because of their faith in Christ.
9. **7<sup>th</sup> Seal of Judgment.** The opening of the 7<sup>th</sup> seal introduces the Seven Trumpet Judgments, which are all judgments of God sent on the earth. In these judgments, God is exclusively the sender, and the people are exclusively the receivers. These judgments are so terrible that the angels stand breathless in wonder. As the seventh seal is broken, seven angels receive trumpets. This introduces the 2<sup>nd</sup> quarter of the Tribulation.

## Revelation Chapter 7

### Revelation 7:1-3

*Then I saw four angels standing at the four corners of the earth, holding back the four winds from blowing upon the earth. Not a leaf rustled in the trees, and the sea became as smooth as glass. <sup>2</sup> And I saw another angel coming from the east, carrying the seal of the living God. And he shouted out to those four angels who had been given power to injure land and sea, <sup>3</sup> “Wait! Don’t hurt the land or the sea or the trees until we have placed the seal of God on the foreheads of his servants.”*

1. At this time, God will seal His people with a mark on their foreheads. We do not know of what this seal will look like, but the text suggests it will be visible on the forehead. Antichrist will also be forcing people to take his mark at this time. Both marks are final. Once a person receives the Antichrist as his master, he has made his decision for eternity. The same will be true for those who accept Christ. We are also introduced to the fact that God will be supernaturally protecting those who belong to Him. Those in Christ will not suffer from some of the effects of the judgments.

### Revelation 7:4-8

*<sup>4</sup> And I heard how many were marked with the seal of God. There were 144,000 who were sealed from all the tribes of Israel:*

<i>from Judah</i>	<i>12,000</i>
<i>from Reuben</i>	<i>12,000</i>
<i>from Gad</i>	<i>12,000</i>
<i>from Asher</i>	<i>12,000</i>
<i>from Naphtali</i>	<i>12,000</i>
<i>from Manasseh</i>	<i>12,000</i>
<i>from Simeon</i>	<i>12,000</i>
<i>from Levi</i>	<i>12,000</i>
<i>from Issachar</i>	<i>12,000</i>
<i>from Zebulun</i>	<i>12,000</i>
<i>from Joseph</i>	<i>12,000</i>
<i>from Benjamin</i>	<i>12,000</i>

2. The identity of the 144,000 is revealed. It is very clear these are redeemed Jews, 12,000 from each tribe. Two of the tribes named are different from those listed in the original twelve of the Old Testament. The tribes of Dan and Ephraim lost their inheritance because of their idolatry. Although all of the tribes were guilty of this, Dan and Ephraim were more rebellious than the others. Levi and Joseph substitute for the two tribes.

We know they are redeemed, because they have the seal of God. Joel's description of the outpouring of the Holy Spirit experienced on the day of Pentecost will be the type experienced by the 144,000 witnesses of the Tribulation. Today there are Jewish people living all over the world. They are already in place. They know the language. They know the culture. And God will pour His Spirit into these Jews. They will become like Paul and preach the Gospel of Salvation through Christ to the world. The 144,000 will take over the assignment of the Church to evangelize the world. Chapter 14 tells us that they are not married, so they are completely without family responsibility and available to do the work of God. There is no more mention of the 144,000 shortly after Mid-Tribulation, so we can assume that they all have been killed by Antichrist. The church, as it is, will again be under Jewish control and evangelism will be world wide as it was in the Apostolic Church.

### **Revelation 7:9-12**

*After this I saw a vast crowd, too great to count, from every nation and tribe and people and language, standing in front of the throne and before the Lamb. They were clothed in white and held palm branches in their hands. <sup>10</sup> And they were shouting with a mighty shout, "Salvation comes from our God on the throne and from the Lamb!" <sup>11</sup> And all the angels were standing around the throne and around the elders and the four living beings. And they fell face down before the throne and worshiped God. <sup>12</sup> They said, "Amen! Blessing and glory and wisdom and thanksgiving and honor and power and strength belong to our God forever and forever. Amen!"*

3. John saw a great multitude from every nation, tribe, people and language. And they were wearing white robes showing they were redeemed. This was a result of the 144,000 Jewish evangelists. Their zeal for service to God will be compared to that of the apostle Paul and many will be saved during this time.

### **Revelation 7:13-17**

*<sup>13</sup> Then one of the twenty-four elders asked me, "Who are these who are clothed in white? Where do they come from?" <sup>14</sup> And I said to him, "Sir, you are the one who knows." Then he said to me, "These are the ones coming out of the great Tribulation. They washed their robes in the blood of the Lamb and made them white. <sup>15</sup> That is why they are standing in front of the throne of God, serving him day and night in his Temple. And he who sits on the throne will live among them and shelter them. <sup>16</sup> They will never again be hungry or thirsty, and they will be fully protected from the scorching noontime heat. <sup>17</sup> For the Lamb who stands in front of the throne will be their Shepherd. He will lead them to the springs of life-giving water. And God will wipe away all their tears.*

4. The effects of the Rapture, plus the Holy Spirit filled 144,000 Jewish evangelist, plus all of the chaos in the world, plus the world's population, will equal a time of more people converted to Christ than the entire Christian Dispensation. In other words, more people will be saved during the Tribulation than all of the people saved from the time of Christ's death to the Rapture.

## Revelation Chapter 8

### Revelation 8:1-5

*When the Lamb broke the seventh seal, there was silence throughout heaven for about half an hour. <sup>2</sup> And I saw the seven angels who stand before God, and they were given seven trumpets.*

*<sup>3</sup> Then another angel with a gold incense burner came and stood at the altar. And a great quantity of incense was given to him to mix with the prayers of God's people, to be offered on the gold altar before the throne. <sup>4</sup> The smoke of the incense, mixed with the prayers of the saints, ascended up to God from the altar where the angel had poured them out. <sup>5</sup> Then the angel filled the incense burner with fire from the altar and threw it down upon the earth; and thunder crashed, lightning flashed, and there was a terrible earthquake.*

1. **7<sup>th</sup> Seal of Judgment.** The opening of the 7<sup>th</sup> seal introduces the Seven Trumpet Judgments, which are all judgments of God sent on the earth and carried out by angels. God is exclusively the sender of these judgments, and the people are exclusively the receivers. These judgments are so terrible that the angels stand breathless in wonder. As the seventh seal is broken, seven angels receive trumpets. This introduces the 2<sup>nd</sup> quarter of the Tribulation. Angels carry out the first six judgments. There is only one judgment that God will carry out Himself and that is the last one.
2. The silence for 30 minutes is unheard of in heaven. We have been told by John that there is always much singing and praising of God. He has told us of thousands and thousands of angels singing and now the next judgments are so terrible that they are silent.

### Revelation 8:6-7

*<sup>6</sup> Then the seven angels with the seven trumpets prepared to blow their mighty blasts. <sup>7</sup> The first angel blew his trumpet, hail and fire mixed with blood were thrown down upon the earth, and one-third of the earth was set on fire. One-third of the trees were burned, and all the grass was burned.*

3. **1st Trumpet Judgment.** Hail and fire mixed with blood are literal judgments that fall on 1/3 of the earth's surface, burning up all the vegetation they fall upon.

### Revelation 8:7-9

*<sup>8</sup> Then the second angel blew his trumpet, and a great mountain of fire was thrown into the sea. And one-third of the water in the sea became blood. <sup>9</sup> And one-third of all things living in the sea died. And one-third of all the ships on the sea were destroyed.*

4. **2<sup>nd</sup> Trumpet Judgment.** What appeared to John as a “*huge mountain*” is probably a giant meteorite that falls into the seas killing 1/3 of the living creatures and destroying 1/3 of the ships. The result of that death and the chemical composition of the meteorite turn the water to blood. There is some speculation that the reference is to the Mediterranean Sea, where the world will have many ships. As Antichrist is rebuilding Babylon as his capitol, this part of the world will be center stage.

### **Revelation 8:10-11**

<sup>10</sup> *Then the third angel blew his trumpet, and a great flaming star fell out of the sky, burning like a torch. It fell upon one-third of the rivers and on the springs of water.* <sup>11</sup> *The name of the star was Bitterness. It made one-third of the water bitter, and many people died because the water was so bitter.*

5. **3<sup>rd</sup> Trumpet Judgment.** This introduces us to a burning “*torch*” that visibly falls from heaven, indicating it is another meteorite. When this meteorite called “*Wormwood*” strikes, it will hit at a place where the headwaters of three great rivers come together. It will bury itself so deep and at just the right spot that it pollutes 1/3 of the rivers waters supply and those dependent on the rivers will die.

### **Revelation 8:12**

<sup>12</sup> *Then the fourth angel blew his trumpet, and one-third of the sun was struck, and one-third of the moon, and one-third of the stars, and they became dark. And one-third of the day was dark and one-third of the night also.*

6. **4<sup>th</sup> Trumpet Judgment.** God, who is light, will diminish it by 1/3. Day and night will seem to be reversed, for there will be sixteen hours of darkness and eight hours of light. Jesus spoke of this judgment in Luke 21: 25-26, “*There will be signs in the sun, moon and stars.*”

### **Revelation 8:13**

<sup>13</sup> *Then I looked up. And I heard a single eagle crying loudly as it flew through the air, “Terror, terror, terror to all who belong to this world because of what will happen when the last three angels blow their trumpets.”*

7. The warning by this special angel, in the form of an eagle, introduces the 3 woes, which are the 5<sup>th</sup>, 6<sup>th</sup>, and 7<sup>th</sup> Trumpet Judgments. These last judgments get progressively more destructive and can be describe as “*hell on earth.*” This verse informs us that as horrible as the first 4 Trumpet Judgments have been. They will be surpassed in misery by that which will follow. The rebellion of people against God gets progressively worse.

Aware that they have sinned against God and are in the middle of judgments placed on them by the Lamb, they persist in their stubborn self-will against God.

8. As we will see in Chapter 17, the Great Prostitute (the world religious system), *who is drunk with the blood of the saints*, continues to kill Christians and anyone who opposes her position. This is sanctioned and encourage by the Antichrist. As we approach the Middle of the Tribulation, he is gaining more and more power and blames all of the judgments on the Two Witnesses, who are introduced in Chapter 11. They have been on the scene since the beginning, when Israel signed the covenant with Antichrist. When we get to the end of the Trumpet Judgments, things will change greatly.

## Revelation Chapter 9

### Revelation 9:1-12

*Then the fifth angel blew his trumpet, and I saw a star that had fallen to earth from the sky, and he was given the key to the shaft of the bottomless pit. <sup>2</sup> When he opened it, smoke poured out as though from a huge furnace, and the sunlight and air were darkened by the smoke.*

*<sup>3</sup> Then locusts came from the smoke and descended on the earth, and they were given power to sting like scorpions. <sup>4</sup> They were told not to hurt the grass or plants or trees but to attack all the people who did not have the seal of God on their foreheads. <sup>5</sup> They were told not to kill them but to torture them for five months with agony like the pain of scorpion stings. <sup>6</sup> In those days people will seek death but will not find it. They will long to die, but death will flee away!*

*<sup>7</sup> The locusts looked like horses armed for battle. They had gold crowns on their heads, and they had human faces. <sup>8</sup> Their hair was long like the hair of a woman, and their teeth were like the teeth of a lion. <sup>9</sup> They wore armor made of iron, and their wings roared like an army of chariots rushing into battle. <sup>10</sup> They had tails that stung like scorpions, with power to torture people. This power was given to them for five months. <sup>11</sup> Their king is the angel from the bottomless pit; his name in Hebrew is Abaddon, and in Greek, Apollyon—the Destroyer.*

*<sup>12</sup> The first terror is past, but look, two more terrors are coming!*

1. **The 1<sup>st</sup> Woe or the 5<sup>th</sup> Trumpet Judgment.** Fallen star (angel) is given the key to the bottomless pit and releases locusts with power to sting like scorpions. The indication is that this angel was in heaven and therefore would be an angel that has not rebelled against God. He has been given the responsibility of holding this key until God's appointed time.
2. The Abyss or bottomless pit is not hell or Hades. It is a place of discomfort for evil demons. Scripture indicates two kinds of demons: 1) *those that are living in the spiritual realm and seeking individuals to torment, and 2) those confined in "gloomy dungeons to be held for judgment."* (2 Peter 2:4)
3. When the Abyss is opened, smoke rises up from it until the air is saturated with a thick smog-like condition. Out of the smog will come locust-like scorpion creatures. These creatures are shaped like locusts, but with bodies like horses, faces like men, hair like women, and teeth like lions. They have breastplates of iron, their wings will sound like *"the thundering of many horses rushing into battle,"* and they possess stings in their tails similar to scorpions. They are not to be interpreted literally, nor symbolically, but spiritually, for they are a spirit creature able to bring about physical pain on humanity.

4. These awful creatures will come with the purpose of persecuting people who do not have the mark of God on their forehead. More than likely, we will not be able to see them. Their king is Apollyon, which means destroyer in Greek. (Rev. 9:11) They will not harm vegetation or animals, only humans. They will not kill them, but will torment them with the horrible sting of a scorpion. This is one of the most painful stings known. It is seldom fatal, but sets the entire nervous system on fire. The torment of this stinging will last 5 months without reprieve.

### **Revelation 9:13-21**

*<sup>13</sup> Then the sixth angel blew his trumpet, and I heard a voice speaking from the four horns of the gold altar that stands in the presence of God. <sup>14</sup> And the voice spoke to the sixth angel who held the trumpet: “Release the four angels who are bound at the great Euphrates River.” <sup>15</sup> And the four angels who had been prepared for this hour and day and month and year were turned loose to kill one-third of all the people on earth. <sup>16</sup> They led an army of 200 million mounted troops—I heard an announcement of how many there were.*

*<sup>17</sup> And in my vision, I saw the horses and the riders sitting on them. The riders wore armor that was fiery red and sky blue and yellow. The horses’ heads were like the heads of lions, and fire and smoke and burning sulfur billowed from their mouths. <sup>18</sup> One-third of all the people on earth were killed by these three plagues—by the fire and the smoke and burning sulfur that came from the mouths of the horses. <sup>19</sup> Their power was in their mouths, but also in their tails. For their tails had heads like snakes, with the power to injure people. <sup>20</sup> But the people who did not die in these plagues still refused to turn from their evil deeds. They continued to worship demons and idols made of gold, silver, bronze, stone, and wood—idols that neither see nor hear nor walk! <sup>21</sup> And they did not repent of their murders or their witchcraft or their immorality or their thefts.*

1. **The 2<sup>nd</sup> Woe or 6<sup>th</sup> Trumpet Judgment.** Four angels, who are bound at the great river Euphrates, are released. We know they are evil spirits because they were bound. They are very anxious to wreak havoc on humans. It states they have been “*kept ready for this very hour and day and month and year and were released to kill 1/3 of mankind.*” Those slain are no doubt incorrigibles who would never accept Christ and would only serve as a hindrance to undecided people, those who have not taken the mark of the beast.
2. There will be an army of 200 million horse-like creatures with riders on their backs called, “*horsemen.*” The four angels bound and released seem to be the leaders of this army. These are evil spirits, riding on horse like creatures, having heads like lions and emitting smoke, fire and sulfur. They have tails like serpents, from which their power is sent forth. These creatures will kill 1/3 of what’s left of the world’s population.

3. We have already seen 25 percent of the population killed by the 4 Horsemen of the Apocalypse. This slaughter will be of another billion and half people. The total of both of these killings will be about 3 billion people or about half of the world's population by today's numbers. The people killed by these evil spirits will be people that don't have the mark of God on their foreheads.
  
4. This Trumpet judgment brings us to the end of the first ½ of the Tribulation. We find that about 50% of the world's population has died. Either killed by the judgments of God or by the Antichrist for not taking his mark. During the Tribulation period people will have many opportunities to accept God, as they see His judgments.

## Revelation Chapter 10

### Revelation 10:1-11

*Then I saw another mighty angel coming down from heaven, surrounded by a cloud, with a rainbow over his head. His face shone like the sun, and his feet were like pillars of fire. <sup>2</sup> And in his hand was a small scroll, which he had unrolled. He stood with his right foot on the sea and his left foot on the land. <sup>3</sup> And he gave a great shout, like the roar of a lion. And when he shouted, the seven thunders answered.*

*<sup>4</sup> When the seven thunders spoke, I was about to write. But a voice from heaven called to me: “Keep secret what the seven thunders said. Do not write it down.”*

*<sup>5</sup> Then the mighty angel standing on the sea and on the land lifted his right hand to heaven. <sup>6</sup> And he swore an oath in the name of the one who lives forever and ever, who created heaven and everything in it, the earth and everything in it, and the sea and everything in it. He said, “God will wait no longer. <sup>7</sup> But when the seventh angel blows his trumpet, God’s mysterious plan will be fulfilled. It will happen just as he announced it to his servants the prophets.”*

*<sup>8</sup> Then the voice from heaven called to me again: “Go and take the unrolled scroll from the angel who is standing on the sea and on the land.”*

*<sup>9</sup> So I approached him and asked him to give me the little scroll. “Yes, take it and eat it,” he said. “At first it will taste like honey, but when you swallow it, it will make your stomach sour!” <sup>10</sup> So I took the little scroll from the hands of the angel, and I ate it! It was sweet in my mouth, but it made my stomach sour.*

*<sup>11</sup> Then he said to me, “You must prophesy again about many peoples, nations, languages, and kings.”*

1. John describes a mighty angel that is standing with his right foot in the sea and his left foot on the earth, indicating that he has authority over all land and sea surfaces. He then cries in a loud voice, which signals the seven thunder-like voices.
2. John is preparing to write down what these voices say, but then hears another voice telling him to, “*seal up what the seven thunders have said and do not write it down.*” We may never know what John heard and was told to seal up. We can ask when we get to heaven, but even then we may never know.
3. The angel is standing on the earth and sea. By this we can assume John is not in heaven, but on the earth. He apparently returned to the earth with the little scroll. The scroll is concerning future events that take place on the earth.

4. After John asks the angel for the scroll, he is told to take it and eat it, though he is warned it will be sweet to taste at first and bitter to the belly. John more than likely actually ate a small scroll. It is also a symbolic reference to digesting the Word of God. Note in Jeremiah 15:16; *“When your words came, I ate them; they were my joy and my heart’s delight, for I bear your name, O Lord God almighty.”* Ezekiel 3:1-3 contains the admonition of the Lord to the Old Testament prophet to *“eat this scroll,”* and it *“tasted as sweet as honey in my mouth.”*
  
5. After he had eaten the scroll, John was told to speak to the house of Israel. The angel tells him after he has eaten it, that he must prophesy to many peoples, nations, languages and kings. Through the written book of Revelation, John fulfills this. The sweetness comes to John in the prediction concerning our Lord’s return; the bitterness comes to John in being confronted by the fact that judgment is pronounced on the earth.

# Revelation Chapter 11

## Revelation 11:1-14

*Then I was given a measuring stick, and I was told, "Go and measure the Temple of God and the altar, and count the number of worshipers." <sup>2</sup> But do not measure the outer courtyard, for it has been turned over to the nations. They will trample the holy city for 42 months. <sup>3</sup> And I will give power to my two witnesses, and they will be clothed in sackcloth and will prophesy during those 1,260 days."*

*<sup>4</sup> These two prophets are the two olive trees and the two lampstands that stand before the Lord of all the earth. <sup>5</sup> If anyone tries to harm them, fire flashes from the mouths of the prophets and consumes their enemies. This is how anyone who tries to harm them must die. <sup>6</sup> They have power to shut the skies so that no rain will fall for as long as they prophesy. And they have the power to turn the rivers and oceans into blood, and to send every kind of plague upon the earth as often as they wish.*

*<sup>7</sup> When they complete their testimony, the beast that comes up out of the bottomless pit will declare war against them. He will conquer them and kill them. <sup>8</sup> And their bodies will lie in the main street of Jerusalem, the city which is called "Sodom" and "Egypt," the city where their Lord was crucified. <sup>9</sup> And for three and a half days, all peoples, tribes, languages, and nations will come to stare at their bodies. No one will be allowed to bury them. <sup>10</sup> All the people who belong to this world will give presents to each other to celebrate the death of the two prophets who had tormented them.*

*<sup>11</sup> But after three and a half days, the spirit of life from God entered them, and they stood up! And terror struck all who were staring at them. <sup>12</sup> Then a loud voice shouted from heaven, "Come up here!" And they rose to heaven in a cloud as their enemies watched.*

*<sup>13</sup> And in the same hour there was a terrible earthquake that destroyed a tenth of the city. Seven thousand people died in that earthquake. And everyone who did not die was terrified and gave glory to the God of heaven.*

*<sup>14</sup> The second terror is past, but look, now the third terror is coming quickly.*

1. At some point in the beginning of the Tribulation, two colorful and dynamic individuals come on the scene as special witnesses of God. We do not know where they have come from, but are told God will give them power. They will be able to send fire out of their mouths to kill those that try to persecute them. They will also have power to over the heavens so it does not rain, and the earth will have a great drought. They also will have power over waters to turn them to blood and to smite the earth with plagues.

2. There is a lot of speculation as to the identity of these two prophets. Most think they are Elijah and Moses. They are Jews who prophesy and minister to Israel. And the fact that they have supernatural power indicates they have come directly from heaven.
3. What is more important is the work they are sent to do. They will be warning people about the judgments and calling them to repentance. They will be on the scene during the first half of the Tribulation to counteract the lying of the Antichrist. They will help those who come to Christ to know the truth, as the Antichrist will be deceiving the world and telling many lies. They will also be preaching the Gospel regarding salvation through Christ.
4. No one will be able to harm them until the appointed time. They will speak out against the Antichrist and he will want them dead. He kills them after 1260 days of prophecy. Their bodies lie on the street for 3 ½ days as people from every tribe, language and nation gaze on their bodies and refuse to bury them. The fact that it is possible today for the whole world to witness something like this via television is another indication that we are closer to the end of this age.
5. Not content to just look on their dead bodies, the people of the world will celebrate their death and enjoy a “Christmas-like” time, giving gifts and receiving gifts because these preachers of righteousness and holiness are dead. After 3 ½ days suddenly *“a breath of life from God will enter them, and they will stand on their feet.”* Then a cloud will receive them into the heavens and out of the sight of their enemies. Terror will strike all that see this. The resurrection of these two men will be the final confirmation that they were men of God.
6. This is the scripture Mid-Tribulation believers use to explain their belief that Christians will go through the first ½ of the Tribulation. Because a voice from heaven says to them to *“come up here,”* and they go in a cloud. But these two witnesses are not New Testament Christians. They are Jews who prophesy and minister to Israel. And there has been no mention of the Church since Chapter 4.

### **Revelation 11:15-19**

<sup>15</sup> *Then the seventh angel blew his trumpet, and there were loud voices shouting in heaven: “The whole world has now become the kingdom of our Lord and of his Christ, and he will reign forever and ever.”*

<sup>16</sup> *And the twenty-four elders sitting on their thrones before God fell on their faces and worshiped him. <sup>17</sup> And they said, “We give thanks to you, Lord God Almighty, the one who is and who always was,*

*for now you have assumed your great power  
and have begun to reign.*

<sup>18</sup>*The nations were angry with you,*

*but now the time of your wrath has come.*

*It is time to judge the dead and reward your servants.*

*You will reward your prophets and your holy people,*

*all who fear your name, from the least to the greatest.*

*And you will destroy all who have caused destruction on the earth.”*

<sup>19</sup> *Then, in heaven, the Temple of God was opened and the Ark of his covenant could be seen inside the Temple. Lightning flashed, thunder crashed and roared; there was a great hailstorm, and the world was shaken by a mighty earthquake.*

1. **The 3rd Woe or the 7<sup>th</sup> Trumpet Judgment.** The 7<sup>th</sup> Trumpet Judgment is the beginning of the 7 Bowl Judgments. When the angel shouts “*the whole world has now become the Kingdom of our Lord,*” this is to let us know that when this last set of judgments are through; Christ will reign here on earth. These will be the worst of all the judgments. Those before the throne of God give us a brief justification of these judgments. They state that God has been warning that they were coming and that it is time. His people will be rewarded and those who did not receive Him will face His wrath. John gets a view of the Temple of God that is in heaven and he sees the Ark of the Covenant. This may be the ark that the nation of Israel had and has never been found.

## Revelation Chapter 12

### Revelation 12:1-6

*Then I witnessed in heaven an event of great significance. I saw a woman clothed with the sun, with the moon beneath her feet, and a crown of twelve stars on her head. <sup>2</sup> She was pregnant, and she cried out in the pain of labor as she awaited her delivery.*

*<sup>3</sup> Suddenly, I witnessed in heaven another significant event. I saw a large red dragon with seven heads and ten horns, with seven crowns on his heads. <sup>4</sup> His tail dragged down one-third of the stars, which he threw to the earth. He stood before the woman as she was about to give birth to her child, ready to devour the baby as soon as it was born.*

*<sup>5</sup> She gave birth to a boy who was to rule all nations with an iron rod. And the child was snatched away from the dragon and was caught up to God and to his throne. <sup>6</sup> And the woman fled into the wilderness, where God had prepared a place to give her care for 1,260 days.*

1. Verse 1 describes a woman, “*clothed with the sun, with the moon under her feet.*” She is Israel as God’s Light bearer to humankind. Verse 2 tells us she is about to give birth to her Messiah.
2. Verse 3 describes the dragon with seven heads, each having horns and seven crowns. This is Satan. Verse 4 brings us back briefly to the beginning of the war between the angels or stars and God. This was the time when Lucifer (Satan) was cast out of heaven with a 1/3 of the angels. (Isaiah 14:12-15) Verse 4 continues to the time of the birth of Christ. The Dragon, or Satan, is waiting to devour the woman’s child thus preventing Christ from accomplishing His goal.
3. When Satan deceived man and man sinned, man’s relationship with God was broken and death entered the world. God then promised man that He would send a Child to restore man to God. So Satan watched and waited for the Child to be born and knew that it would come through Israel.
4. Verse 5 takes us back to Christ’s birth, death, resurrection, and future kingdom.
5. Verse 6 jumps to the middle of the Tribulation, when Israel realizes she has been deceived by the Antichrist and turns to God for help. God supernaturally intervenes to save Israel. She must hide for 1260 days or 3 ½ years from the Antichrist.
6. 1260 days is 3½ years. This is how long she must hide. It shows us we are at the middle of the Tribulation period. Israel will flee after they realize they have signed a contract with the devil.

7. Satan will go into the rebuilt Temple and set himself up to be worshipped. This comes from Daniel 9:27, “*He will make a treaty with the people for a period of one set of seven, but after half this time, he will put an end to the sacrifices and offerings.*” Then as a climax to all his terrible deeds, Satan will set up a sacrilegious object that causes desecration.

### **Revelation 12:7-9**

<sup>7</sup> *Then there was war in heaven. Michael and the angels under his command fought the dragon and his angels. <sup>8</sup> And the dragon lost the battle and was forced out of heaven. <sup>9</sup> This great dragon—the ancient serpent called the Devil, or Satan, the one deceiving the whole world—was thrown down to the earth with all his angels.*

8. Verse 7 tells us about a great battle that takes place in heaven between Satan and Michael. Up until this time, Satan has had limited access to the throne of God. We know this because of Job. In Job God speaks directly to Satan, “*Have you considered My servant Job?*” It also states that Satan is before the throne of God accusing the saints day and night. But at this time Satan is defeated by Michael and is completely cast out of Heaven and is sent to the earth. This is not the original battle when Lucifer rebelled against God.
9. Verse 8 tells us that Satan will lose this battle and will be forced from heaven. This battle happens at the mid point of the Tribulation. Satan is completely cast out of all parts of heaven and no longer has any access to the throne of God.
10. Verse 9 tells us that Satan and all his angels are cast down to the earth. This makes Satan very angry, and he goes after the woman and anyone who confesses they belong to Christ. This is the beginning of the Great Tribulation, or 2<sup>nd</sup> half of the Tribulation. It is after this event that Satan brings the dead Antichrist back to life and lives in his body. (Antichrist receives a fatal wound and dies. He has been completely human up to this point, but controlled by Satan. After he is killed and resurrected, Satan takes his body and lives in him as ruler of the world.)

### **Revelation 12:10-12**

<sup>10</sup> *Then I heard a loud voice shouting across the heavens, “It has happened at last—the salvation and power and kingdom of our God, and the authority of his Christ! For the Accuser has been thrown down to earth—the one who accused our brothers and sisters before our God day and night. <sup>11</sup> And they have defeated him because of the blood of the Lamb and because of their testimony. And they were not afraid to die.*

*<sup>12</sup> Rejoice, O heavens! And you who live in the heavens, rejoice! But terror will come on the earth and the sea. For the Devil has come down to you in great anger, and he knows that he has little time.”*

11. Verse 10 reveals a triumphant shout declaring that finally it has happened. The accuser can no longer stand before God and accuse the children of God of their sin.
12. Verse 11 states that because the saints defeated Satan by their testimony, he is cast completely out of heaven. Because they were not afraid to die, the devil is defeated. This warns that more Tribulation saints will die.
13. Verse 12 tells us those in heaven will rejoice. But warns those children of God still living on the earth that Satan is very angry and that he will come after the woman and those who serve God.

### **Revelation 12: 13-18**

*<sup>13</sup> And when the dragon realized that he had been thrown down to the earth, he pursued the woman who had given birth to the child. <sup>14</sup> But she was given two wings like those of a great eagle. This allowed her to fly to a place prepared for her in the wilderness, where she would be cared for and protected from the dragon for a time, times, and half a time.*

*<sup>15</sup> Then the dragon tried to drown the woman with a flood of water that flowed from its mouth. <sup>16</sup> But the earth helped her by opening its mouth and swallowing the river that gushed out from the mouth of the dragon. <sup>17</sup> Then the dragon became angry at the woman, and he declared war against the rest of her children—all who keep God’s commandments and confess that they belong to Jesus. <sup>18</sup> Then he stood waiting on the shore of the sea.*

14. Verse 13 states that when Satan realizes he has been defeated and cast out of heaven, he will pursue the woman. The woman or Israel will be given supernatural power by God in verse 14. She will be allowed to flee from Satan into a place God has already prepared. Many believe that place will be Petra. She will be protected from Satan for 3 ½ years. This is another indication we are at the mid point of the Tribulation.
15. Verse 15 tells us that Satan will try and drown her by sending a great flood. But in verse 16, God will help her by opening up the earth to swallow the water. This makes Satan even angrier and he declares war on the woman and anyone who confesses that they belong to Jesus in verse 17.
16. Verse 18 is an introduction to Chapter 13 which tells us about the Beast out of the sea.

## Revelation Chapter 13

### Revelation 13:1-6

*And now in my vision I saw a beast rising up out of the sea. It had seven heads and ten horns, with ten crowns on its horns. And written on each head were names that blasphemed God. <sup>2</sup> This beast looked like a leopard, but it had bear's feet and a lion's mouth! And the dragon gave him his own power and throne and great authority.*

*<sup>3</sup> I saw that one of the heads of the beast seemed wounded beyond recovery—but the fatal wound was healed! All the world marveled at this miracle and followed the beast in awe. <sup>4</sup> They worshiped the dragon for giving the beast such power, and they worshiped the beast. “Is there anyone as great as the beast?” they exclaimed. “Who is able to fight against him?”*

1. The Antichrist is the beast rising out of the sea. He is called many things, “*little horn,*” “*the ruler who will com,*” “*man of lawlessness,*” and “*beast coming of the sea.*” Here we are told that it is the Dragon, or Satan, that gives the Beast his power. The seven heads each with ten horns and ten crowns, refers to the kingdoms that the Beast will rule over.
2. One of the heads on the Beast is mortally wounded, but comes back to life. This is the Beast as stated in Rev. 17:8, “*the beast which you saw, once was, now is not, and will come up out of the Abyss and go to his destruction.*” The Beast himself is killed, but his kingdom will continue, as the other heads will rule in his brief absence as they do not realize that that he will return.
3. Daniel 9:26 refers to him as “*the ruler that will come.*” Meaning that he will be of the royal lineage that destroyed Jerusalem. Dan. 11:36-37 tells us that he regards not, “*the God of his fathers.*” This would suggest that he is Jewish. In all probability, he will appear to be a Gentile and will keep his Jewish blood a secret.
4. Satan enters into the dead body of Antichrist and raises him from the dead. Satan is now indwelling the Antichrist and things get worse for the world and Israel. He will rise to power with diplomacy and dominate a one-world government and a one-world economy. He will approve an ecumenical world church. But his true religion is atheism. And he will set himself up to be god by mid Tribulation. But he is on his way to ultimate destruction.

### **Revelation 13:7-10**

*<sup>7</sup> And the beast was allowed to wage war against God's holy people and to overcome them. And he was given authority to rule over every tribe and people and language and nation. <sup>8</sup> And all the people who belong to this world worshiped the beast. They are the ones whose names were not written in the Book of Life, which belongs to the Lamb who was killed before the world was made.*

*<sup>9</sup> Anyone who is willing to hear should listen and understand. <sup>10</sup> The people who are destined for prison will be arrested and taken away. Those who are destined for death will be killed. But do not be dismayed, for here is your opportunity to have endurance and faith.*

5. The seven Seal and Trumpet Judgments have taken place. We have now reached the mid point of the Tribulation period. The beast has been killed and comes back to life as Satan incarnate. Satan has no access to the throne of God and can no longer stand before God and accuse the saints of our sins. Things are going to go from bad to worse for the Tribulation saints and the Jews.
6. The Antichrist is now given authority over the entire world and he is allowed to wage war and overcome God's people. But as we read in verse 5 it is only for 42 months or 3 ½ years.
7. Everyone whose name is not written in the Lambs Book of Life will worship the Beast.
8. Verse 9 is a message to the Tribulation saints. They are told that those destined for prison will go and those destined for death will die. But God will give them strength to endure and faith to persevere.

### **Revelation 13:11-18**

*<sup>11</sup> Then I saw another beast come up out of the earth. He had two horns like those of a lamb, and he spoke with the voice of a dragon. <sup>12</sup> He exercised all the authority of the first beast. And he required all the earth and those who belong to this world to worship the first beast, whose death-wound had been healed. <sup>13</sup> He did astounding miracles, such as making fire flash down to earth from heaven while everyone was watching. <sup>14</sup> And with all the miracles he was allowed to perform on behalf of the first beast, he deceived all the people who belong to this world. He ordered the people of the world to make a great statue of the first beast, who was fatally wounded and then came back to life. <sup>15</sup> He was permitted to give life to this statue so that it could speak. Then the statue commanded that anyone refusing to worship it must die.*

<sup>16</sup> He required everyone—great and small, rich and poor, slave and free—to be given a mark on the right hand or on the forehead. <sup>17</sup> And no one could buy or sell anything without that mark, which was either the name of the beast or the number representing his name. <sup>18</sup> Wisdom is needed to understand this. Let the one who has understanding solve the number of the beast, for it is the number of a man. His number is 666.

9. The Beast coming out of the earth is the False Prophet. The suggestion is that he is an apostate Jew who will work with Antichrist to deceive the Jewish nation. That he is a lamb suggests that he will appear meek and mild. The horns indicate that he will demand complete worship of the image he makes of Antichrist. That he spoke like a dragon indicates his power comes from Satan. He will enforce the power of Antichrist and make the entire world worship the first beast. He is the Antiholy Spirit. He will be allowed to perform many miracles to deceive those who do not serve Christ. He will cause the image of the first Beast to come alive and command that “*anyone refusing to worship (it) must die.*”
10. Everyone will be required to be given a mark on “*the right hand or on the forehead.*” The number of the beast (666) will somehow mathematically speak the name of the Antichrist. But this number will be his. Without it, no one will be able to buy or sell anything. Spiritually speaking, it will be fatal to have the mark. There will be no salvation for those that take it. Once taken, the person will be given completely over to Satan, and there will be no protection from God. Today even those not saved live under an umbrella of God’s protection. But once the mark of the Beast is taken, there will be no protection.

## Revelation Chapter 14

### Revelation 14:1-5

*Then I saw the Lamb standing on Mount Zion, and with him were 144,000 who had his name and his Father's name written on their foreheads. <sup>2</sup> And I heard a sound from heaven like the roaring of a great waterfall or the rolling of mighty thunder. It was like the sound of many harpists playing together.*

*<sup>3</sup> This great choir sang a wonderful new song in front of the throne of God and before the four living beings and the twenty-four elders. And no one could learn this song except those 144,000 who had been redeemed from the earth. <sup>4</sup> For they are spiritually undefiled, pure as virgins, following the Lamb wherever he goes. They have been purchased from among the people on the earth as a special offering to God and to the Lamb. <sup>5</sup> No falsehood can be charged against them; they are blameless.*

1. The 144,000 are all of the Jewish evangelists who are in Heaven with Christ by mid Tribulation. These verses describe them surrounding the throne of God with the four seraphim and the 24 elders.

### Revelation 14:6-13

*<sup>6</sup> And I saw another angel flying through the heavens, carrying the everlasting Good News to preach to the people who belong to this world—to every nation, tribe, language, and people. <sup>7</sup> “Fear God,” he shouted. “Give glory to him. For the time has come when he will sit as judge. Worship him who made heaven and earth, the sea, and all the springs of water.”*

*<sup>8</sup> Then another angel followed him through the skies, shouting, “Babylon is fallen—that great city is fallen—because she seduced the nations of the world and made them drink the wine of her passionate immorality.”*

*<sup>9</sup> Then a third angel followed them, shouting, “Anyone who worships the beast and his statue or who accepts his mark on the forehead or the hand <sup>10</sup> must drink the wine of God's wrath. It is poured out undiluted into God's cup of wrath. And they will be tormented with fire and burning sulfur in the presence of the holy angels and the Lamb. <sup>11</sup> The smoke of their torment rises forever and ever, and they will have no relief day or night, for they have worshiped the beast and his statue and have accepted the mark of his name. <sup>12</sup> Let this encourage God's holy people to endure persecution patiently and remain firm to the end, obeying his commands and trusting in Jesus.”*

*<sup>13</sup> And I heard a voice from heaven saying, “Write this down: Blessed are those who die in the Lord from now on. Yes, says the Spirit, they are blessed indeed, for they will rest from all their toils and trials; for their good deeds follow them!”*

2. With the 144,000 now in heaven, God sends three angels to fly over the world to proclaim to the remaining people to fear God, to give Him glory and to not worship the image. They warn the people of God's coming wrath. They also encourage the remaining faithful to hold on and trust Jesus. Imagine how encouraging it will be to those who love the Lord to see and hear these angels at this terrible time in history.

**14:14-20**

*<sup>14</sup> Then I saw the Son of Man sitting on a white cloud. He had a gold crown on his head and a sharp sickle in his hand.*

*<sup>15</sup> Then an angel came from the Temple and called out in a loud voice to the one sitting on the cloud, "Use the sickle, for the time has come for you to harvest; the crop is ripe on the earth." <sup>16</sup> So the one sitting on the cloud swung his sickle over the earth, and the whole earth was harvested.*

*<sup>17</sup> After that, another angel came from the Temple in heaven, and he also had a sharp sickle. <sup>18</sup> Then another angel, who has power to destroy the world with fire, shouted to the angel with the sickle, "Use your sickle now to gather the clusters of grapes from the vines of the earth, for they are fully ripe for judgment." <sup>19</sup> So the angel swung his sickle on the earth and loaded the grapes into the great winepress of God's wrath. <sup>20</sup> And the grapes were trodden in the winepress outside the city, and blood flowed from the winepress in a stream about 180 miles long and as high as a horse's bridle.*

3. This is a description of Christ about to harvest the world and separate the wheat from the chaff. The whole earth being harvested is the final judgment that Christ will deliver. The time for judgment has come and the "grapes" or people who worshipped the Beast will be killed. The blood from this judgment will flow in a stream 180 miles long and as high as a horses bridle. This will take place outside of Jerusalem at a place called Megiddo.

## Revelation Chapter 15

### Revelation 15:1-4

*Then I saw in heaven another significant event, and it was great and marvelous. Seven angels were holding the seven last plagues, which would bring God's wrath to completion.<sup>2</sup> I saw before me what seemed to be a crystal sea mixed with fire. And on it stood all the people who had been victorious over the beast and his statue and the number representing his name. They were all holding harps that God had given them.<sup>3</sup> And they were singing the song of Moses, the servant of God, and the song of the Lamb:*

*“Great and marvelous are your actions,*

*Lord God Almighty.*

*Just and true are your ways,*

*O King of the nations.*

<sup>4</sup> *Who will not fear, O Lord, and glorify your name?*

*For you alone are holy.*

*All nations will come and worship before you,*

*for your righteous deeds have been revealed.”*

1. John tells us about what he is seeing. First he saw the last seven angels holding the last judgments. And he saw all those that did not take the mark of the Beast and did not worship his image and were killed on earth. They are standing on a crystal sea mixed with fire and they are singing a song of praise to God for His coming judgments. They are stating that the judgments are just and that God is holy.

### Revelation 15:5-8

<sup>5</sup> *Then I looked and saw that the Temple in heaven, God's Tabernacle, was thrown wide open!* <sup>6</sup> *The seven angels who were holding the bowls of the seven plagues came from the Temple, clothed in spotless white linen with gold belts across their chests.* <sup>7</sup> *And one of the four living beings handed each of the seven angels a gold bowl filled with the terrible wrath of God, who lives forever and forever.* <sup>8</sup> *The Temple was filled with smoke from God's glory and power. No one could enter the Temple until the seven angels had completed pouring out the seven plagues.*

2. This begins the last judgments or the 7 Bowl Judgments. When the 7<sup>th</sup> angel blows his trumpet, 7 angels come out of the Temple in heaven and each is holding a bowl filled with plagues. Each one is handed another bowl by the one of the 4 living beings around the throne of God. Each one of these bowls is filled with God's wrath and each one will be poured out upon the earth.

# Revelation Chapter 16

## Revelation 16:1-2

*Then I heard a mighty voice shouting from the Temple to the seven angels, “Now go your ways and empty out the seven bowls of God’s wrath on the earth.”<sup>2</sup> So the first angel left the Temple and poured out his bowl over the earth, and horrible, malignant sores broke out on everyone who had the mark of the beast and who worshiped his statue.*

1. **1st Bowl Judgment.** Boils break out on the people who have the mark of the beast and worship his image. Boils are one of the most painful sores known to man.

## Revelation 16:3

*Then the second angel poured out his bowl on the sea, and it became like the blood of a corpse. And everything in the sea died.*

2. **2nd Bowl Judgment.** God has already caused a 1/3 of the sea to become blood. This plague causes the entire sea to turn to blood. All the living creatures in the sea die. Imagine all of the dead sea creatures floating to the top. Their decaying bodies causing horrible stench and disease. This will interfere with shipping and will deplete a major food source for the world.

## Revelation 16:4-7

*Then the third angel poured out his bowl on the rivers and springs, and they became blood.<sup>5</sup> And I heard the angel who had authority over all water saying, “You are just in sending this judgment, O Holy One, who is and who always was.<sup>6</sup> For your holy people and your prophets have been killed, and their blood was poured out on the earth. So you have given their murderers blood to drink. It is their just reward.”<sup>7</sup> And I heard a voice from the altar saying, “Yes, Lord God Almighty, your punishments are true and just.”*

3. **3<sup>rd</sup> Bowl Judgment.** The people and prophets martyred for God are finally getting justice. In this plague God will destroy the only remaining water sources the world has, the rivers and springs. Many will die. But as we have already seen, God will supernaturally provide for Israel who will be hiding from the Antichrist.

## Revelation 16:8-9

*Then the fourth angel poured out his bowl on the sun, causing it to scorch everyone with its fire.<sup>9</sup> Everyone was burned by this blast of heat, and they cursed the name of God, who sent all of these plagues. They did not repent and give him glory.*

4. **4<sup>th</sup> Bowl Judgment.** When this judgment falls, humans will have to contend with a sun-induced heat wave that has never been seen before. Even with a 3<sup>rd</sup> of the sun darkened, it will be so powerful that it will scorch people “*with fire.*” Imagine not having water and then having to deal with burns and the extreme heat.

#### **Revelation 16:10-11**

*Then the fifth angel poured out his bowl on the throne of the beast, and his kingdom was plunged into darkness. And his subjects ground their teeth in anguish,<sup>11</sup> and they cursed the God of heaven for their pains and sores. But they refused to repent of all their evil deeds.*

5. **5<sup>th</sup> Bowl Judgment.** Many look at this judgment as an act of mercy from God. This judgment is centered on the Antichrist and his kingdom. They are plunged into darkness. This darkness will prevail for some time. The Bible states, “*men gnawed their tongues in agony,*” which indicates that the relief from the heat will soon produce exasperating, frustrating darkness. It will be into this darkness that Christ will return.

#### **Revelation 16:12-16**

*Then the sixth angel poured out his bowl on the great Euphrates River, and it dried up so that the kings from the east could march their armies westward without hindrance.<sup>13</sup> And I saw three evil spirits that looked like frogs leap from the mouth of the dragon, the beast, and the false prophet.<sup>14</sup> These miracle-working demons caused all the rulers of the world to gather for battle against the Lord on that great judgment day of God Almighty.*

<sup>15</sup> *“Take note: I will come as unexpectedly as a thief! Blessed are all who are watching for me, who keep their robes ready so they will not need to walk naked and ashamed.”*

<sup>16</sup> *And they gathered all the rulers and their armies to a place called Armageddon in Hebrew.*

6. **6<sup>th</sup> Bowl Judgment.** There are two parts to this judgment. First the Euphrates River dries up, allowing the kings from the east to move west. This is in preparation for the Battle at the Glorious Appearing of Christ. Then there are 3 evil spirits that are released. They look like frogs and they incite more rebellion in the kings of the world to gather for battle on the great day of God Almighty. These demons assist Antichrist and the False Prophet in convincing the kings of the world that they can beat Christ when He comes.

## Revelation 16:16-21

<sup>16</sup> *And they gathered all the rulers and their armies to a place called Armageddon in Hebrew.*

<sup>17</sup> *Then the seventh angel poured out his bowl into the air. And a mighty shout came from the throne of the Temple in heaven, saying, "It is finished!"* <sup>18</sup> *Then the thunder crashed and rolled, and lightning flashed. And there was an earthquake greater than ever before in human history.* <sup>19</sup> *The great city of Babylon split into three pieces, and cities around the world fell into heaps of rubble. And so God remembered all of Babylon's sins, and he made her drink the cup that was filled with the wine of his fierce wrath.* <sup>20</sup> *And every island disappeared, and all the mountains were leveled.* <sup>21</sup> *There was a terrible hailstorm, and hailstones weighing seventy-five pounds fell from the sky onto the people below. They cursed God because of the hailstorm, which was a very terrible plague.*

7. **7<sup>th</sup> Bowl Judgment.** When this last judgment is poured out, a voice will be heard stating, "*It is finished!*" This concludes the Great Tribulation period. In chapter 16, verse 19 "*Babylon*" is mentioned specifically. Chapter 17 and 18 give us the details concerning the destruction of Babylon. She is described as the Great Whore. The Great Whore and Babylon have been on the scene since the beginning of the Tribulation. It was mentioned in chapter 14, verse 8, which says, "*And there followed another angel, saying, Babylon is fallen, is fallen, that great city, because she made all nations drink of the wine of the wrath of her fornication.*" Finally, we get the description of the Glorious appearing in Chapter 19.
8. A great earthquake will be followed by a hailstorm. The earthquake is of a magnitude that has never been seen or felt before. It will completely destroy the Antichrist's capitol, Babylon, and Jerusalem. It will literally divide the "*great city*" into three parts. Although the center of the earthquake is in Jerusalem, it is not confined to Jerusalem. We are told that "*the cities of the nations fell.*" This tells us of the extent and the vast destruction of the earthquake.
9. After the earthquake the earth will be laid bare. Great hailstones weighing 75 pounds each will fall from heaven. It is difficult for us to imagine this or imagine anyone living through all of this, but many do.
10. Thousands of years before this judgment will happen, Joel 3:12-14 described what was to come.

- <sup>12</sup> *You must come now  
to Judgment Valley,  
where the LORD will judge  
the surrounding nations.*
- <sup>13</sup> *They are a field of ripe crops.  
Bring in the harvest!  
They are grapes piled high.  
Start trampling them now!  
If our enemy's sins were wine,  
every jar would overflow.*
- <sup>14</sup> *Crowds fill Decision Valley.  
The judgment day of the LORD  
will soon be here—*
- <sup>15</sup> *no light from the sun or moon,  
and stars no longer shine.*
- <sup>16</sup> *From the heart of Jerusalem  
the LORD roars like a lion,  
shaking the earth and sky.*

11. Scholars disagree about the exact location of this place, but the most likely possibility is the valley between Mount Carmel and the city of Jezreel. This valley (known as the Valley of Jezreel and sometimes referred to as the Plain of Esdraelon) was the crossroads of two ancient trade routes and thus was a strategic military site and the scene of many ancient battles.

## Revelation Chapter 17

### Revelation 17:1-6

*One of the seven angels who had poured out the seven bowls came over and spoke to me. “Come with me,” he said, “and I will show you the judgment that is going to come on the great prostitute, who sits on many waters.”<sup>2</sup> The rulers of the world have had immoral relations with her, and the people who belong to this world have been made drunk by the wine of her immorality.”*

*<sup>3</sup> So the angel took me in spirit into the wilderness. There I saw a woman sitting on a scarlet beast that had seven heads and ten horns, written all over with blasphemies against God.<sup>4</sup> The woman wore purple and scarlet clothing and beautiful jewelry made of gold and precious gems and pearls. She held in her hand a gold goblet full of obscenities and the impurities of her immorality.<sup>5</sup> A mysterious name was written on her forehead: “Babylon the Great, Mother of All Prostitutes and Obscenities in the World.”<sup>6</sup> I could see that she was drunk—drunk with the blood of God’s holy people who were witnesses for Jesus. I stared at her completely amazed.*

1. John is transported into the wilderness in the spirit by the angel. Though not stated this vision takes place in the middle of the Tribulation. The first six verses give us a picture of two great forces, one religious and the other governmental. It is a description of the global ecumenical religious system that is powerful enough to gain a controlling influence in the Antichrist’s government. The Great Prostitute is the false church. That she “*sits on many waters*” represent the masses of people from every nation and language that follow her into rebellion against God. “*The rulers of the world who had immoral relations with her*” show that there is an unholy alliance between church and state during that period. And the Scarlet Beast is the restored Roman Empire, which will be brought back together by Antichrist with assistance of the false church.
2. The woman sitting on the head of the Beast is the Prostitute and the Beast is the Antichrist. That she sits on him shows she has power over him.
3. The Prostitute has been involved in immorality with the kings of the world to help the Beast gain control of the world and they have enjoyed their sin.
4. This governmental system uses the Prostitute to gain control over the world but will hate her for it. Now he (the system or Antichrist) wants to set himself up as the world religion.

5. The woman is dressed in fine clothing and jewelry showing that she is very wealthy. The gold goblet filled with obscenities shows that she gained her wealth by sinful ways. More than likely by lying and cheating and from taking money from those she had power over.
6. She is called Mystery Babylon. Mystery does not mean unexplainable, but rather never before revealed. She is the mother of all prostitutes because she represents all idolatrous religions. All organized idolatrous religions began in Babylon with Nimrod and his mother. (Genesis 11)
7. She is drunk with the blood of God's saints. During the first ½ of the Tribulation the Beast will use the Prostitute to do his dirty work by killing those that do not believe in her false teaching. Any way to God will be accepted except salvation through Christ. And there will be no sin except believing in Christ in this church. Those who do not agree and are caught will be put to death by her.
8. All of the kings most likely represent the kings that reside in the old Roman Empire, rather than one particular city. They all hate her and plot to destroy her.

### **Revelation 17:7-18**

<sup>7</sup> "Why are you so amazed?" the angel asked. "I will tell you the mystery of this woman and of the beast with seven heads and ten horns. <sup>8</sup> The beast you saw was alive but isn't now. And yet he will soon come up out of the bottomless pit and go to eternal destruction. And the people who belong to this world, whose names were not written in the Book of Life from before the world began, will be amazed at the reappearance of this beast who had died.

<sup>9</sup> "And now understand this: The seven heads of the beast represent the seven hills of the city where this woman rules. They also represent seven kings. <sup>10</sup> Five kings have already fallen, the sixth now reigns, and the seventh is yet to come, but his reign will be brief. <sup>11</sup> The scarlet beast that was alive and then died is the eighth king. He is like the other seven, and he, too, will go to his doom. <sup>12</sup> His ten horns are ten kings who have not yet risen to power; they will be appointed to their kingdoms for one brief moment to reign with the beast. <sup>13</sup> They will all agree to give their power and authority to him. <sup>14</sup> Together they will wage war against the Lamb, but the Lamb will defeat them because he is Lord over all lords and King over all kings, and his people are the called and chosen and faithful ones." <sup>15</sup> And the angel said to me, "The waters where the prostitute is sitting represent masses of people of every nation and language. <sup>16</sup> The scarlet beast and his ten horns—which represent ten kings who will reign with him—all hate the prostitute. They will strip her naked, eat her flesh,

*and burn her remains with fire.<sup>17</sup> For God has put a plan into their minds, a plan that will carry out his purposes. They will mutually agree to give their authority to the scarlet beast, and so the words of God will be fulfilled.<sup>18</sup> And this woman you saw in your vision represents the great city that rules over the kings of the earth.”*

9. John is amazed by all that he sees and the angel tells him what he is looking at. With the 7<sup>th</sup> angel blowing his trumpet, all of heaven considers the Bowl Judgments completed. The Beast who was alive but now is dead is the Antichrist. He will go to the Bottomless Pit at the end of the Tribulation and then go to his final destruction.
10. The seven heads are seven hills on which the woman sits. This has caused some to speculate that since Rome sits on seven hills, it must be the city of the Great Prostitute. This may be but Rome as we know it today as the center of the Catholic Church will not exist. Rather it will be a combination of all world churches. The seven heads are also seven kings that rule with Antichrist. He starts out with ten and three are killed. These are the remaining seven.
11. Verse 10 states, *“Five kings have already fallen, the sixth now reigns, and the seventh is yet to come, but his reign will be brief,”* and refers to the heads of the Roma Empire.
  1. Julius Caesar—assassinated
  2. Tiberius—poisoned or smothered
  3. Caligula—assassinated
  4. Claudius—poisoned
  5. Nero—committed suicide

*“The sixth now reigns”* refers to Domitian who was living in John’s day, who was also assassinated. *“The seventh yet to come”* refers to the Antichrist.
12. Antichrist will die in the middle of the Tribulation period. He will duplicate the resurrection of Jesus Christ by coming back to life. Verse 11 refers to Satan when he enters Antichrist body to rule the world. But he will finally be completely destroyed at the end of the Tribulation.
13. The ten horns are the ten kings that will make up the Antichrist’s world confederacy of nations. They will wage war with the Antichrist against the Christians. They all hate the Prostitute and God will put a plot into their minds for them to carry out His judgment against the Great Prostitute.

## Revelation Chapter 18

### Revelation 18:1-24

*After all this I saw another angel come down from heaven with great authority, and the earth grew bright with his splendor. <sup>2</sup> He gave a mighty shout, “Babylon is fallen—that great city is fallen! She has become the hideout of demons and evil spirits, a nest for filthy buzzards, and a den for dreadful beasts. <sup>3</sup> For all the nations have drunk the wine of her passionate immorality. The rulers of the world have committed adultery with her, and merchants throughout the world have grown rich as a result of her luxurious living.”*

*And all the ship owners and captains of the merchant ships and their crews will stand at a distance. <sup>18</sup> They will weep as they watch the smoke ascend, and they will say, “Where in all the world is there another city like this?” <sup>19</sup> And they will throw dust on their heads to show their great sorrow. And they will say, “How terrible, how terrible for the great city! She made us all rich from her great wealth. And now in a single hour it is all gone.”*

*<sup>20</sup> But you, O heaven, rejoice over her fate. And you also rejoice, O holy people of God and apostles and prophets! For at last God has judged her on your behalf.*

*<sup>21</sup> Then a mighty angel picked up a boulder as large as a great millstone. He threw it into the ocean and shouted, “Babylon, the great city, will be thrown down as violently as I have thrown away this stone, and she will disappear forever. <sup>22</sup> Never again will the sound of music be heard there—no more harps, songs, flutes, or trumpets. There will be no industry of any kind, and no more milling of grain. <sup>23</sup> Her nights will be dark, without a single lamp. There will be no happy voices of brides and grooms. This will happen because her merchants, who were the greatest in the world, deceived the nations with her sorceries. <sup>24</sup> In her streets the blood of the prophets was spilled. She was the one who slaughtered God’s people all over the world.”*

1. At some point toward the end of the Tribulation, Babylon will be utterly destroyed. We know that Babylon has already been destroyed as Jeremiah and Isaiah predicted. So how can it be destroyed again? It will have to be rebuilt at some point before or during the Tribulation.
2. It is clear that Babylon is the trade center of the world and that many will get rich from trading with her. While the Great Prostitute shows us the world religious system, Babylon is the world economical system. Both have relied on their own power to gain control and both deny God. The kings that rule with Antichrist will do the same and God will destroy them. Many today use these systems to meet their needs instead of giving glory to God for His power.

3. Before we can get to the Marriage Supper of the Lamb, we need to understand what takes place before this wedding dinner. This is the judgment of the righteous dead, which takes place at some point before the Marriage Supper of the Lamb and after the Rapture, during the Tribulation. This is called the Bema Seat of Christ. Bema in Greek is translated “to go.” Meaning the path or the way. It is also translated a “judgment seat.” So Christ will be examining each Christian for the path they took during their life here on earth. This will not be a judgment for sin, but will be for the life of the Christian after they have made a decision for Christ. He will be handing our rewards for the work Christians did in His name using the talents He gave them. We will all stand before Christ.
4. *1 Corinthians 3:10-15* states, “According to the grace of God which was given to me, as a wise master builder I have laid the foundation, and another builds on it. But let each one take heed how he builds on it. For no other foundation can anyone lay than that which is laid, which is Jesus Christ. Now if anyone builds on this foundation with gold, silver, precious stones, wood, hay, straw, each one’s work will become clear; for the Day will declare it, because it will be revealed by fire; and the fire will test each one’s work, of what sort it is. If anyone’s work which he has built on it endures, he will receive a reward. If anyone’s work is burned, he will suffer loss; but he himself will be saved, yet so as through fire.
5. At this judgment all people will be saved and will be in heaven, but everyone will have to go before Jesus Christ and give an account of what they did with the talents He gave them and how they used them to carry out the great commission.
6. The parable of the talents in *Matthew 25:14-29* states that we all have been given talents to use for Christ. We will be judged on our hearts intent for the deeds we did in His name. Did we do it for His glory or ours?
7. For our part, all we need to do is say, “yes” to God. We do this by reading scripture, praying and letting Him work through us. Our works cannot be done with our own power or direction. They must be done through the power of the Holy Spirit and with His direction. This is what we will have to account for.
8. Our reward will be fine linens as stated in Rev. 19:8. This is what we will be wearing to the Marriage Supper of the Lamb.

9. There are also five crowns mentioned in scripture that we will be given as rewards.

**Rev. 2:10 Crown of Life**

**1 Peter 5:2-4 Crown of Glory**

**2 Tim 4:18 Crown of Righteousness**

**1 Thess. 2:19-20 Crown of Rejoicing**

**1 Cor. 9:25 Victors Crown**

## Revelation Chapter 19

### Revelation 19:1-10

*After this, I heard the sound of a vast crowd in heaven shouting, “Hallelujah! Salvation is from our God. Glory and power belong to him alone.”<sup>2</sup> His judgments are just and true. He has punished the great prostitute who corrupted the earth with her immorality, and he has avenged the murder of his servants.”<sup>3</sup> Again and again their voices rang, “Hallelujah! The smoke from that city ascends forever and forever!”*

*<sup>4</sup> Then the twenty-four elders and the four living beings fell down and worshiped God, who was sitting on the throne. They cried out, “Amen! Hallelujah!”*

*<sup>5</sup> And from the throne came a voice that said, “Praise our God, all his servants, from the least to the greatest, all who fear him.”*

*<sup>6</sup> Then I heard again what sounded like the shout of a huge crowd, or the roar of mighty ocean waves, or the crash of loud thunder: “Hallelujah! For the Lord our God, the Almighty, reigns.”<sup>7</sup> Let us be glad and rejoice and honor him. For the time has come for the wedding feast of the Lamb, and his bride has prepared herself.<sup>8</sup> She is permitted to wear the finest white linen.” (Fine linen represents the good deeds done by the people of God.)*

*<sup>9</sup> And the angel said, “Write this: Blessed are those who are invited to the wedding feast of the Lamb.” And he added, “These are true words that come from God.”*

*<sup>10</sup> Then I fell down at his feet to worship him, but he said, “No, don’t worship me. For I am a servant of God, just like you and other brothers and sisters who testify of their faith in Jesus. Worship God. For the essence of prophecy is to give a clear witness for Jesus.”*

1. The vast crowd in heaven is singing praises to Christ stating that His judgments are just and true. There is much praising and singing in heaven because the Marriage Supper of the Lamb is about to begin. This happens right before the 7<sup>th</sup> Bowl judgment. The return of Christ to the Earth is the honeymoon for Christ and His bride the Church. The Judgment of the Righteous dead (or Bema Seat) is complete and the Supper is about to take place.
2. John is told again not to worship the angel and he tells John the essence of all prophecy is to give a clear picture of Christ.

### Revelation 19:11-21

*<sup>11</sup> Then I saw heaven opened, and a white horse was standing there. And the one sitting on the horse was named Faithful and True. For he judges fairly and then goes to war.<sup>12</sup> His eyes were bright like flames of fire, and on his head were many crowns. A name was written on him, and only he knew what it*

meant. <sup>13</sup> He was clothed with a robe dipped in blood, and his title was the Word of God. <sup>14</sup> The armies of heaven, dressed in pure white linen, followed him on white horses. <sup>15</sup> From his mouth came a sharp sword, and with it he struck down the nations. He ruled them with an iron rod, and he trod the winepress of the fierce wrath of almighty God. <sup>16</sup> On his robe and thigh was written this title: King of kings and Lord of lords.

<sup>17</sup> Then I saw an angel standing in the sun, shouting to the vultures flying high in the sky: “Come! Gather together for the great banquet God has prepared. <sup>18</sup> Come and eat the flesh of kings, captains, and strong warriors; of horses and their riders; and of all humanity, both free and slave, small and great.”

<sup>19</sup> Then I saw the beast gathering the kings of the earth and their armies in order to fight against the one sitting on the horse and his army. <sup>20</sup> And the beast was captured, and with him the false prophet who did mighty miracles on behalf of the beast—miracles that deceived all who had accepted the mark of the beast and who worshiped his statue. Both the beast and his false prophet were thrown alive into the lake of fire that burns with sulfur. <sup>21</sup> Their entire army was killed by the sharp sword that came out of the mouth of the one riding the white horse. And all the vultures of the sky gorged themselves on the dead bodies.

3. There is another description of Christ coming to judge a world that has rejected Him. We are the army of heaven and we follow Him riding white horses dressed in white. His robe is dipped in blood and out of His mouth comes a sharp two-edged sword that He uses to destroy his enemies. It is His Word that will kill the Antichrist’s army. He is the King of kings and the Lord of lords, Jesus Christ.
4. This battle is stated best in **Zechariah 14:1** “Watch, for the day of the LORD is coming when your possessions will be plundered right in front of you! On that day I will gather all the nations to fight against Jerusalem. The city will be taken, the houses plundered, and the women raped. Half the population will be taken away into captivity, and half will be left among the ruins of the city. Then the LORD will go out to fight against those nations, as he has fought in times past. On that day his feet will stand on the Mount of Olives, which faces Jerusalem on the east. And the Mount of Olives will split apart, making a wide valley running from east to west, for half the mountain will move toward the north and half toward the south. You will flee through this valley, for it will reach across to Azal. Yes, you will flee as you did from the earthquake in the days of King Uzziah of Judah. Then the LORD my God will come, and all his holy ones with him.”

5. Verses 12-13 of Zechariah states, *“And the LORD will send a plague on all the nations that fought against Jerusalem. Their people will become like walking corpses, their flesh rotting away. Their eyes will shrivel in their sockets, and their tongues will decay in their mouths. On that day they will be terrified, stricken by the Lord with great panic. They will fight against each other in hand-to-hand combat.”*
6. Verse 19 of Revelation gives us a description of the 7<sup>th</sup> Bowl judgment or the Battle of Armageddon. This battle takes place at the Valley of Megiddo. We will not do any fighting as Christ will smite them with the Sword of His Mouth, and the rest will kill each other. As we have already read, the armies of the world have been gathering to fight Christ, incited by the 3 evil frog-like spirits.
7. The people who come out to fight against Christ will all be killed. Those who have the mark of the Beast and do not come out to battle will be dealt with at a later time.
8. The Beast and the False Prophet are thrown into the Lake of Fire at this time for their rebellion against God. Satan will be thrown into the Bottomless Pit.

## Revelation Chapter 20

### Revelation 20:1-3

*Then I saw an angel come down from heaven with the key to the bottomless pit and a heavy chain in his hand. <sup>2</sup> He seized the dragon—that old serpent, the Devil, Satan—and bound him in chains for a thousand years. <sup>3</sup> The angel threw him into the bottomless pit, which he then shut and locked so Satan could not deceive the nations anymore until the thousand years were finished. Afterward he would be released again for a little while.*

1. No created being has caused more suffering than Satan. He is finally bound and thrown into the Bottomless Pit by another angel. It is shut and locked. He will stay there for 1000 years and not be able to deceive the nations anymore until the 1000 years are finished. The angel comes down from heaven to the Bottomless Pit which tells us that it is located on the earth somewhere. Satan's time is up; he can deceive no more that is why this angel does not have a fight from him.

### Revelation 20:4-6

*<sup>4</sup> Then I saw thrones, and the people sitting on them had been given the authority to judge. And I saw the souls of those who had been beheaded for their testimony about Jesus, for proclaiming the word of God. And I saw the souls of those who had not worshiped the beast or his statue, nor accepted his mark on their forehead or their hands. They came to life again, and they reigned with Christ for a thousand years. <sup>5</sup> This is the first resurrection. (The rest of the dead did not come back to life until the thousand years had ended.) <sup>6</sup> Blessed and holy are those who share in the first resurrection. For them the second death holds no power, but they will be priests of God and of Christ and will reign with him a thousand years.*

2. There are two groups of redeemed; the people sitting on the thrones are the righteous dead before the Tribulation. All those from the beginning of time until the Rapture took place. All the righteous dead at that point were raised from the dead and given glorified bodies like Christ had when He walked on the earth after His resurrection. The next group of people are those who died during the Tribulation. They were beheaded for not worshiping the Beast or his statue. Their dead bodies are resurrected and given a body, just like we were at the rapture. 1 Corinthians 6:14 states, "And God will raise our bodies from the dead by his marvelous power, just as he raised our Lord from the dead." Just as we were raised so the Tribulation saints will be raised. We will all reign with Christ for 1000 years here on the earth.

3. The resurrection of the righteous dead is called the first resurrection. The rest that do not come back to life are the unrighteous dead. They remain in the grave or Hell for another 1000 years. Those who are part of the first resurrection are blessed and spared from the second death, which is the Lake of Fire.
4. The redeemed reign with Christ for 1000 years. We will have bodies and will work along side those people who lived through the Tribulation. Those people will marry and repopulate the earth. We will be working in Christ government and will have different positions of power over the people on the earth. We will be in positions of judgment and will execute it under the authority of Christ.
5. The Millennium (Revelation 20:6)

Isaiah 65: 17-25 best describes this period of time.

*“Look! I am creating new heavens and a new earth—so wonderful that no one will even think about the old ones anymore. <sup>18</sup> Be glad; rejoice forever in my creation! And look! I will create Jerusalem as a place of happiness. Her people will be a source of joy. <sup>19</sup> I will rejoice in Jerusalem and delight in my people. And the sound of weeping and crying will be heard no more. <sup>20</sup> “No longer will babies die when only a few days old. No longer will adults die before they have lived a full life. No longer will people be considered old at one hundred! Only sinners will die that young! <sup>21</sup> In those days, people will live in the houses they build and eat the fruit of their own vineyards. <sup>22</sup> It will not be like the past, when invaders took the houses and confiscated the vineyards. For my people will live as long as trees and will have time to enjoy their hard-won gains. <sup>23</sup> They will not work in vain, and their children will not be doomed to misfortune. For they are people blessed by the LORD, and their children, too, will be blessed. <sup>24</sup> I will answer them before they even call to me. While they are still talking to me about their needs, I will go ahead and answer their prayers! <sup>25</sup> The wolf and lamb will feed together. The lion will eat straw like the ox. Poisonous snakes will strike no more. In those days, no one will be hurt or destroyed on my holy mountain. I, the LORD, have spoken!”*

### **Revelation 20:7-10**

*<sup>7</sup> When the thousand years end, Satan will be let out of his prison. <sup>8</sup> He will go out to deceive the nations from every corner of the earth, which are called Gog and Magog. He will gather them together for battle—a mighty host, as numberless as sand along the shore. <sup>9</sup> And I saw them as they went up on the broad plain of the earth and surrounded God’s people and the beloved city. But fire from heaven came down on the attacking armies and consumed them.*

*<sup>10</sup> Then the Devil, who betrayed them, was thrown into the lake of fire that burns with sulfur, joining the beast and the false prophet. There they will be tormented day and night forever and ever.*

6. At the end of the 1000 years, Satan is released from the Bottomless Pit, and he comes back to the earth to deceive the nations and people again. And many decide to follow him in his rebellion against Christ. Christ is reigning here on earth and people have lived in perfect conditions, but some will still rebel against Him. All of those born during the Millennium will have to decide for themselves if they will serve the Lord or not. Those who don't will not live for more than a 100 years.
7. The battle will not be long as Christ will defeat them easily with fire from heaven. Satan will join the Beast and False Prophet in the Lake of Fire and so will they forever remain.

### **Revelation 20:11-15**

*<sup>11</sup> And I saw a great white throne, and I saw the one who was sitting on it. The earth and sky fled from his presence, but they found no place to hide. <sup>12</sup> I saw the dead, both great and small, standing before God's throne. And the books were opened, including the Book of Life. And the dead were judged according to the things written in the books, according to what they had done. <sup>13</sup> The sea gave up the dead in it, and death and the grave gave up the dead in them. They were all judged according to their deeds. <sup>14</sup> And death and the grave were thrown into the lake of fire. This is the second death—the lake of fire. <sup>15</sup> And anyone whose name was not found recorded in the Book of Life was thrown into the lake of fire.*

8. The Great White Throne of Judgment takes place after the final revolt. This is the judgment for the unrighteous dead. They will be resurrected to face Christ for their sin and deeds. No one at this judgment will have his or her name in the Lambs Book of Life. All will be thrown into the Lake of Fire. This is the Second Death. This is complete separation from God.
9. We will be present at this judgment. It will be a horrible time and all who are there will be greatly saddened by what happens. All the books will be open and all who have rejected Christ will have everything they have ever done or said be examined. They will see the times when they could have accepted Christ and did not. They will know that because they did not choose Christ, they will be eternally doomed.
10. God will have to erase the memory of this from our minds or we will not be able to enjoy eternity with Him.

## Revelation Chapter 21

### Revelation 21:1-4

*Then I saw a new heaven and a new earth, for the old heaven and the old earth had disappeared. And the sea was also gone. <sup>2</sup> And I saw the holy city, the new Jerusalem, coming down from God out of heaven like a beautiful bride prepared for her husband.*

*<sup>3</sup> I heard a loud shout from the throne, saying, “Look, the home of God is now among his people! He will live with them, and they will be his people. God himself will be with them. <sup>4</sup> He will remove all of their sorrows, and there will be no more death or sorrow or crying or pain. For the old world and its evils are gone forever.”*

1. The Scripture clearly teaches that this present order of creation is to pass away in order to make room for a new heaven and a new earth. The Lord Jesus Christ Himself said, “*Heaven and earth shall pass away*” in Matt. 24:35. The old creation was made for the first Adam. Christ, the Last Adam, has a new creation for His new creatures. “*For, behold, I create new heavens and a new earth: and the former shall not be remembered, nor come into mind.*” (Isa. 65:17) “*For as the new heavens and the new earth, which I will make, shall remain before me, says the LORD, so shall your seed and your name remain.*” (Isa. 66:22)
2. The New Jerusalem is the habitation, the eternal home, which is prepared for the Church. We are the Church and we will live in the New Jerusalem. After the Great White Throne of Judgment, the old earth and heavens will pass away and the new will be created. The New Jerusalem will come down from heaven and God Himself will live with us. Just as Christ will live in Jerusalem on earth during the Millennium, so God the Father will reside in the New Jerusalem. There will be no more evil. Evil is destroyed for eternity.

### Revelation 21:5-8

*<sup>5</sup> And the one sitting on the throne said, “Look, I am making all things new!” And then he said to me, “Write this down, for what I tell you is trustworthy and true.” <sup>6</sup> And he also said, “It is finished! I am the Alpha and the Omega—the Beginning and the End. To all who are thirsty I will give the springs of the water of life without charge! <sup>7</sup> All who are victorious will inherit all these blessings, and I will be their God, and they will be my children. <sup>8</sup> But cowards who turn away from me, and unbelievers, and the corrupt, and murderers, and the immoral, and those who practice witchcraft, and idol worshipers, and all liars—their doom is in the lake that burns with fire and sulfur. This is the second death.”*

3. Christ is speaking to John. Everything will be new and we will drink from the River Life. Christ gives the blessing to all who are victorious. To those who are corrupt He states their fate is the second death, the Lake of Fire.

### **Revelation 21:9-21**

<sup>9</sup> *Then one of the seven angels who held the seven bowls containing the seven last plagues came and said to me, “Come with me! I will show you the bride, the wife of the Lamb.”*

<sup>10</sup> *So he took me in spirit to a great, high mountain, and he showed me the holy city, Jerusalem, descending out of heaven from God.* <sup>11</sup> *It was filled with the glory of God and sparkled like a precious gem, crystal clear like jasper.* <sup>12</sup> *Its walls were broad and high, with twelve gates guarded by twelve angels. And the names of the twelve tribes of Israel were written on the gates.* <sup>13</sup> *There were three gates on each side—east, north, south, and west.* <sup>14</sup> *The wall of the city had twelve foundation stones, and on them were written the names of the twelve apostles of the Lamb.*

<sup>15</sup> *The angel who talked to me held in his hand a gold measuring stick to measure the city, its gates, and its wall.* <sup>16</sup> *When he measured it, he found it was a square, as wide as it was long. In fact, it was in the form of a cube, for its length and width and height were each 1,400 miles.* <sup>17</sup> *Then he measured the walls and found them to be 216 feet thick (the angel used a standard human measure).*

<sup>18</sup> *The wall was made of jasper, and the city was pure gold, as clear as glass.* <sup>19</sup> *The wall of the city was built on foundation stones inlaid with twelve gems: the first was jasper, the second sapphire, the third agate, the fourth emerald,* <sup>20</sup> *the fifth onyx, the sixth carnelian, the seventh chrysolite, the eighth beryl, the ninth topaz, the tenth chrysoprase, the eleventh jacinth, the twelfth amethyst.* <sup>21</sup> *The twelve gates were made of pearls—each gate from a single pearl! And the main street was pure gold, as clear as glass.*

4. The New Jerusalem is a postmillennial city, for we are not given a description of her until the end of the Millennium and the beginning of eternity. The New Jerusalem will be to eternity what the earthly Jerusalem is to the Millennium. The bride of Christ is not the city but those who will live in the city, the Church. The angel gives us a very detailed description of the new city, our future home for eternity.

### **Revelation 21:22-27**

<sup>22</sup> *No temple could be seen in the city, for the Lord God Almighty and the Lamb are its temple.* <sup>23</sup> *And the city has no need of sun or moon, for the glory of God illuminates the city, and the Lamb is its light.* <sup>24</sup> *The nations of the earth will walk in its light, and the rulers of the world will come and bring their glory to it.* <sup>25</sup> *Its gates never close at the end of day because there is no night.*

<sup>26</sup> *And all the nations will bring their glory and honor into the city.* <sup>27</sup> *Nothing evil will be allowed to enter—no one who practices shameful idolatry and dishonesty—but only those whose names are written in the Lamb’s Book of Life.*

5. The New Jerusalem will be independent of the sun and moon for light and life. The One who is light will be there. God will light the new creation directly by His presence.
6. There is no need for a temple because God the Father and the Lamb are present. In verse 24, we are told that the nations of the earth will still be there. Apparently those who lived through the Millennium and did not rebel against Christ will continue to live on the new earth. They will not face judgment and will not die but will live forever with Christ. They will come to the New Jerusalem to worship. Their names will have to be written in the Lambs Book of Life or else they would have been thrown in to the Lake of Fire. But they will live outside of the city and will come to worship God.

## Revelation Chapter 22

### Revelation 22:1-6

*And the angel showed me a pure river with the water of life, clear as crystal, flowing from the throne of God and of the Lamb, <sup>2</sup> coursing down the center of the main street. On each side of the river grew a tree of life, bearing twelve crops of fruit, with a fresh crop each month. The leaves were used for medicine to heal the nations.*

*<sup>3</sup> No longer will anything be cursed. For the throne of God and of the Lamb will be there, and his servants will worship him. <sup>4</sup> And they will see his face, and his name will be written on their foreheads. <sup>5</sup> And there will be no night there—no need for lamps or sun—for the Lord God will shine on them. And they will reign forever and ever.*

*<sup>6</sup> Then the angel said to me, “These words are trustworthy and true: ‘The Lord God, who tells his prophets what the future holds, has sent his angel to tell you what will happen soon.’ ”*

1. In the first Eden there was a river which branched into four rivers. In the Garden of Eden there was a forest of trees among which was the Tree of Life. In the New Jerusalem there will be a river, the Water of Life. The throne of God is a living fountain supplying an abundance of water. “*The tree of life*” is a fruit tree, bearing twelve kinds of fruits each month. There is a continuous supply in abundance and variety. In eternity we *will* eat and drink.
2. Apparently after the last battle the nations that live outside of the city will need some healing and they will come to get it from the leaves of the Tree of Life.
3. The curse put on the earth after the fall in Genesis will finally be removed. For God and Christ will reside with us. We are told again there will be no need of light as they are our light. There will be no night and no darkness at all.
4. We are told in verse 8 why John was given this information. All these things will happen soon. John was instructed this almost 2000 years ago. How much sooner is it today than in his day?

## **Revelation 22:7-21**

<sup>7</sup> *“Look, I am coming soon! Blessed are those who obey the prophecy written in this scroll.”*

<sup>8</sup> *I, John, am the one who saw and heard all these things. And when I saw and heard these things, I fell down to worship the angel who showed them to me. <sup>9</sup> But again he said, “No, don’t worship me. I am a servant of God, just like you and your brothers the prophets, as well as all who obey what is written in this scroll. Worship God!”*

<sup>10</sup> *Then he instructed me, “Do not seal up the prophetic words you have written, for the time is near. <sup>11</sup> Let the one who is doing wrong continue to do wrong; the one who is vile, continue to be vile; the one who is good, continue to do good; and the one who is holy, continue in holiness.”*

<sup>12</sup> *“See, I am coming soon, and my reward is with me, to repay all according to their deeds. <sup>13</sup> I am the Alpha and the Omega, the First and the Last, the Beginning and the End.”*

<sup>14</sup> *Blessed are those who wash their robes so they can enter through the gates of the city and eat the fruit from the tree of life. <sup>15</sup> Outside the city are the dogs—the sorcerers, the sexually immoral, the murderers, the idol worshipers, and all who love to live a lie. <sup>16</sup> “I, Jesus, have sent my angel to give you this message for the churches. I am both the source of David and the heir to his throne. I am the bright morning star.”*

<sup>17</sup> *The Spirit and the bride say, “Come.” Let each one who hears them say, “Come.” Let the thirsty ones come—anyone who wants to. Let them come and drink the water of life without charge. <sup>18</sup> And I solemnly declare to everyone who hears the prophetic words of this book: If anyone adds anything to what is written here, God will add to that person the plagues described in this book. <sup>19</sup> And if anyone removes any of the words of this prophetic book, God will remove that person’s share in the tree of life and in the holy city that are described in this book.*

<sup>20</sup> *He who is the faithful witness to all these things says, “Yes, I am coming soon!”*

*Amen! Come, Lord Jesus!*

<sup>21</sup> *The grace of the Lord Jesus be with you all.*

1. Christ himself gives those who obey the prophecy written by John a blessing. John is again instructed by the angel to not worship him and to write everything down and not seal it up.
2. Christ and the angel are both giving final instructions to John; he is told several times that the time is coming soon.

3. The Lord Jesus asserts His deity: *“I am the Alpha and the Omega, the first and the last, the beginning and the end.”* He said this at the beginning of Revelation, and He concludes with it.
4. Only blood-washed believers have authority over the Tree of Life and access to the Holy City. God has told us that there is no more evil in the new earth. It is a warning to those of us living today to follow Christ.
5. So many today claim that Revelation is not the Word of God. Many do not want to think that a loving God could or would send such judgment on a rejecting world. But is true and it will happen just as John has written. We are given a warning not to add or take anything away from what John has written. Those who add to this book or take anything away will face a harsh judgment from God.
6. *“Come, Lord Jesus”* is the heart cry of every true believer. *“The grace of our Lord Jesus Christ be with you all. Amen.”* The New Testament ends with a benediction of grace upon the believers. Grace is offered to all, but if any man (regardless of his merit) refuses the offer which is extended, he must bear the judgment pronounced in this book. Grace is still offered to man. It is God’s method of saving sinners. Amen

## The Seven Churches of Revelation

Church	Christ	Commendation	Criticism	Correction	Judgment	Promise
<b>Ephesus</b> (2:1-7) Apostolic Church AD 30-100	He who holds the seven stars and walks in the midst of the lampstands	Good works, labor, patience, testing of pseudoapostles, and hating the deeds of Nicolaitans.	You have lost your first love, Jesus Christ	Remember where you once were, repent, and do the first works.	Removal of lampstand	Access to the Tree of Life in Paradise
<b>Smyrna</b> (2:8-11) Persecuted Church AD 100-312	The First and the Last, who was dead and came to life	Works, tribulation, and poverty for Christ's sake.	None	Fear not. Be faithful unto death.	None	A Crown of Life and evasion of the consequences of the second death
<b>Pergamos</b> (2:12-17) Indulged Church AD 312-606	The One who has a sharp two- edge sword	Faithfulness to Christ's name even in the face of martyrdom.	False teachers of the doctrine Balaam and Nicolaitans	Repent! Judgment is coming soon!	Warfare against the church with the sword of Christ's mouth	Sustenance with hidden manna, the possession of a white stone, and a new name
<b>Thyatira</b> (2:18-29) Pagan Church Dark Ages AD 606 to Tribulation	The One with eyes like a flame of fire and feet like fine brass	Love, service, faith, and patience which has continued to grow.	Tolerance of immorality and cults of idolatry	Repent and hold fast to what you have until I come!	Jezebel's followers will go thru the Tribulation and see the killing of their children	Power over the nations, and possession of the Morning Star

# The Seven Churches of Revelation

Church	Christ	Commendation	Complaint	Correction	Judgment	Promise
<b>Sardis</b> (3:1-6) Dead church AD 1520 to Tribulation	The One possessing the seven Spirits of God and the seven stars	A few in Sardis who have not defiled their garments and have kept the faith.	A reputation for life but in actuality they were dead.	Be watchful and strengthen what remains. Hold fast to your faith and repent.	Christ will come as a thief in the night. Meaning He will come without notice.	Being clothed in white garments, permanence in the Book of Life.
<b>Philadelphia</b> (3:7-13) Church Christ Loved AD 1750 to Rapture	The One who is holy and true, holding the key of David	Faithfulness to the Word of Christ	None	None	None	Deliverance from the Tribulation, permanence in the temple of God, and the new name of God
<b>Laodicea</b> (3:14-22) Apostate church AD 1900 to Tribulation	The Amen, the Faithful and True Witness, the Beginning of the creation of God	None	They are lukewarm and overestimate their status before God. Christ is not welcomed in this church.	Seek fervently after genuine spiritual riches and repent of you sins.	Expulsion from the mouth of the Lord	Intimacy of relationship, co-rulership with Christ on His throne

## Daniel's 70 Weeks

The disclosure of the Seventy Weeks prophecy. Daniel 9:24–27

- <sup>24</sup> “A period of seventy sets of seven has been decreed for your people and your holy city to put down rebellion, to bring an end to sin, to atone for guilt, to bring in everlasting righteousness, to confirm the prophetic vision, and to anoint the Most Holy Place. <sup>25</sup> Now listen and understand! Seven sets of seven plus sixty-two sets of seven will pass from the time the command is given to rebuild Jerusalem until the Anointed One comes. Jerusalem will be rebuilt with streets and strong defenses, despite the perilous times.

<sup>26</sup> “After this period of sixty-two sets of seven, the Anointed One will be killed, appearing to have accomplished nothing, and a ruler will arise whose armies will destroy the city and the Temple. The end will come with a flood, and war and its miseries are decreed from that time to the very end. <sup>27</sup> He will make a treaty with the people for a period of one set of seven, but after half this time, he will put an end to the sacrifices and offerings. Then as a climax to all his terrible deeds, he will set up a sacrilegious object that causes desecration, until the end that has been decreed is poured out on this defiler.”
- This is the prophecy delivered by Gabriel which makes this chapter of such great importance in the study of eschatology. (see chart)
- “Seventy weeks” does not mean weeks of seven days. The Hebrew word for “seven” is *shabua*, meaning “a unit of measure.” It would be comparable to our word *dozen*. When it stands alone, it could be a dozen of anything—a dozen eggs, a dozen bananas. So here, “seventy weeks” means seventy sevens. It is to be explained in units of years because Daniel has been reading in Jeremiah about *years*, seventy years. Jeremiah had been preaching and writing that the captivity would be for seventy years. The seventy years of captivity were the specific penalty for violating seventy sabbatic years. That would be seventy sevens, a total of 490 years. In those 490 years, Israel had violated exactly seventy sabbatic years; so they would go into captivity for seventy years. “So the message of the LORD spoken through Jeremiah was fulfilled. The land finally enjoyed its Sabbath rest, lying desolate for seventy years, just as the prophet had said.” (2 Chron. 36:21).

4. The Hebrew people understood that a week was seven years. As shown in Genesis 29:27 *“Fulfill the week of this one and we will give you the other also for the service which you shall serve with me yet seven other years. 28 And Jacob did so, and fulfilled her week.”* It was a common unit of measure at that time in Jewish history. Jacob worked 7 years for Leah and then worked Rachael’s week of another 7 years.

1 week = 7 years  
70 weeks = 490 years  
70 weeks divided into 3 periods:  
7 weeks—62 weeks—1 week

5. There are 3 main divisions of the 70 weeks.

The 1<sup>st</sup> 7 sevens or 49 years was for the rebuilding of the temple in Jerusalem.

Then 62 sevens or 434 years was from the completion of the temple to when Messiah is crucified.

The last seven or 7 years is yet to come. This is the Tribulation period. It begins when Israel signs a covenant with Antichrist, and sacrificing will begin again in the temple. The Tribulation or 70<sup>th</sup> week will end with the Second Coming of Christ.

The 70 weeks are interrupted by the Church Age. This correlates with the Time of the Gentiles, (Luke 21:24, *“They will be brutally killed by the sword or sent away as captives to all the nations of the world. And Jerusalem will be conquered and trampled down by the Gentiles until the age of the Gentiles comes to an end.”*) This period of time is undetermined and is only described as the Age of Grace or the time of the Church. The time of the Gentiles began in 605 B.C. when Israel was no longer under their own rule. The Age of Grace is period of time beginning when the Messiah is crucified until the Rapture. This is the time when anyone can come freely to Christ without hindrance. There will never be an easier time to come to know Christ as Savior. We live in the Age of Grace and it is rapidly coming to an end.

6. The Seventy Weeks concern *“your people,”* the people of Daniel or Israel. *“The holy city,”* is Jerusalem. There is an interruption in the Seventy Weeks. Sixty-nine of those “weeks” have already passed, and one “week” is yet to be fulfilled. This is the Age of Grace, the Church Age

that we are currently in. God has not completed His promises to the Jewish nation. Many believe that God is done with Israel just because they have rejected the Messiah He sent. They think the promises have been transferred to the Church. But this is not true, God will complete all of His promises made to Abraham and David.

7. The decree of Artaxerxes, in the twentieth year of his reign (Neh. 2:1–8), meets the requirements of verse 25. The commandment to rebuild the city of Jerusalem was issued in the month Nisan 445 B.C. This will be our starting point of the Seventy Weeks.
8. The first seven weeks of forty-nine years bring us to 397 B.C. and to Malachi and the end of the Old Testament.
9. Sixty-two weeks, or 434 years, bring us to the Messiah. From the first of the month Nisan to the tenth of Nisan (April 6) B.C. 32, is 173,880 days. Dividing them according to the Jewish year of 360 days, He arrives at 483 years (69 sevens). On this day Jesus rode into Jerusalem, offering Himself for the first time, publicly and officially, as the Messiah.
10. After the 69 weeks, or 483 years, there is a time break. During this time, the Messiah is crucified. He is not recognized as the Messiah by the Jewish people. The temple is destroyed as predicted by Christ 40 years later.
11. The final “*week*” (the seventieth), a period of seven years, is projected into the future and does not follow chronologically the other sixty-nine. The time gap between the sixty-ninth and seventieth weeks is the Age of Grace—unknown to the prophets (Eph. 3:1–12; 1 Pet. 1:10–12). The Seventieth Week is eschatological; it is the final period and is yet unfulfilled.
12. The ruler in verse 26 is Titus, the Roman general who came and destroyed the Jewish Temple in 70 A.D. “*The end will come like a flood,*” meaning it will penetrate everything and go everywhere. And there will be miseries until the very end. So there will be no world peace until Christ is reigning here on earth.

13. Verse 27 then switches to the Antichrist, *‘he will make a treaty with Israel, the people, for one set of sevens or seven years.’* How can Antichrist make a treaty with the Jewish people if they are not a nation? After 70 A.D., they were not a nation. It was difficult for Christians to understand how all of this could take place until they became a nation again in 1948. This is how we know we are at the end of the Age of Grace and will soon enter into the Seventieth Week or the Tribulation.
14. *“But after ½ this time,”* refers to the middle of the Tribulation period. This is the time that Antichrist will put an end to sacrifices. At this time in history, there have not been sacrifices in the Temple of God since 70 A.D. So how can Antichrist put an end to something that is not happening? In order for this to take place, the Temple will have to be rebuilt and the Jewish people will have to begin sacrificing again. All of this is yet to happen. After Antichrist signs the treaty with Israel, they will rebuild the Temple and will begin sacrificing again. This will all take place in the first ½ of the Tribulation period.
15. Mid Tribulation, Antichrist will suffer a fatal blow and come back to life. (Rev. 13:3, *“I saw that one of the heads of the beast seemed wounded beyond recovery—but the fatal wound was healed!”*) He will now be Satan incarnate. The False Prophet will build a statue of him. This is the sacrilegious object. The desecration is Antichrist going into the Temple and setting himself up as god to be worshipped. Christ spoke of this in Matthew 24: 15, *“The time will come when you will see what Daniel the prophet spoke about: the sacrilegious object that causes desecration standing in the holy place”*—reader, pay attention!
16. *“Until the end that has been decreed,”* speaks about the fact that Antichrist’s time is limited. God will only allow him so much time and it is limited. From Daniel’s vision, we know it is only for a period of 7 years.

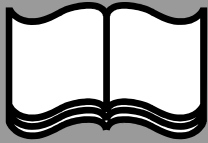

## The Prophecy of the Seventy Weeks (490 years)

Dextee of Artaxerxes March 14, 445 B.C. to Nehemiah—		Presentation of Messiah as Prince—April 6, A.D. 32	Covenant of Antichrist with Israel	Return of Messiah to Establish Kingdom of God
<b>v. 25</b> <b>Sixty-nine Weeks (483 Years)</b>		<b>v. 26</b> <b>Gap of Time</b>	<b>v. 27</b> <b>Seventieth Week (7 years)</b>	
(Seven Weeks) 49 years to Compete Rebuilding of Jerusalem	(Sixty-two Weeks = 434 Years)	Messiah cut off— A.D. 33 Jerusalem and Sanctuary Destroyed A.D. 70	3 1/2 Years  Image of Antichrist in Temple	3 1/2 Years  Desecration by Antichrist  Six Purposes v. 24

# Seal, Trumpet, and Bowl Judgments

Messiah's  
Second  
Coming

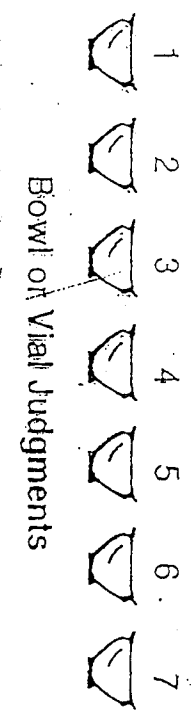
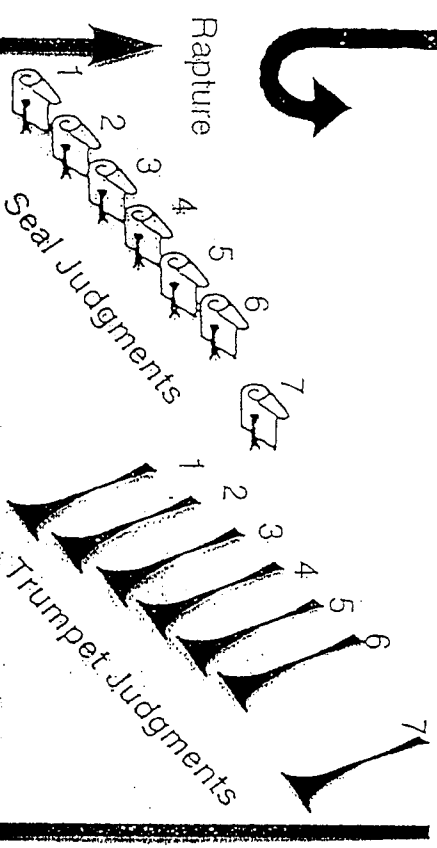

## First Half of Tribulation

## The Great Tribulation

Revelation 6, 8:1-2

Revelation 8, 9, 11:1-15

Revelation 15, 16